



FF SERIES OF SUB ZERO FLAKE ICE MACHINES

(COMPLETE UNIT)

SERVICE MANUAL

(Refrigerant: R404A)

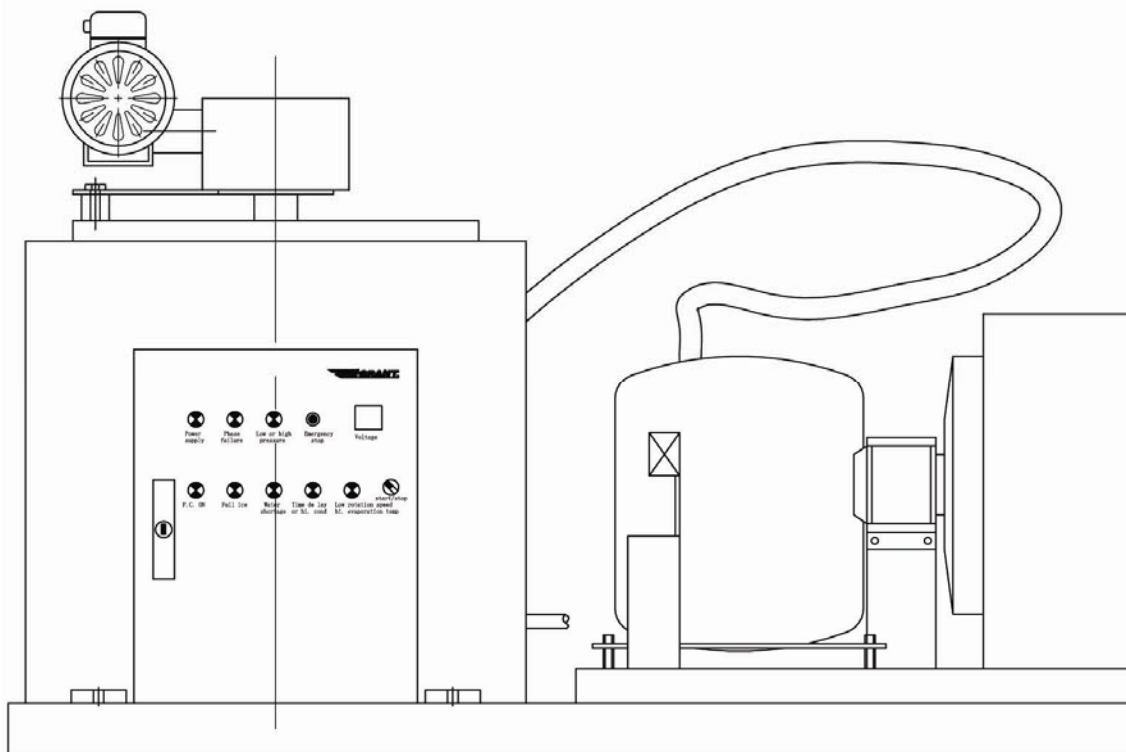

NINGBO GRANT REFRIGERATION EQUIPMENT MANUFACTURING CO., LTD

Table of Contents

I. Overview.....	1
II. Operation Conditions and Performance Parameters	
1. Conditions for Operation of FF Series Sub Zero Ice Machine	1
2. Production Tables	1
3. Specifications	3
4. Working Pressure (Ambient temperature :25□)	3
5. Refrigerant Charges	4
6. Dimensions.....	4
III. Transportation and Installation	
1. Transportation and Handling	5
2. Check on Components	5
3. Installation Guidelines	5
4. Installation Procedures	5
Installation Schematic Diagram for Split Unit.....	6
5. Operating Instruction	7
IV. Operating Principles	
1. Refrigeration System.....	8
2. Water System.....	9
3. Ice level Control System	9
4. The Gearbox	10
5. P.C. Board Control System.....	10
V. Maintenance & Trouble Shooting	
1. Equipment Maintenance.....	11
2. Trouble Shooting	12
VI. Electrical Wiring Diagram.....	13
VII Parts and Components Diagram.....	14
VIII P.C. Board and Sensor Assy.....	15

I. Overview

Read this service manual carefully before installation, troubleshooting and operation of this sub-zero ice machine.

This Service Manual gives an introduction of operation conditions, performance parameters, installation, troubleshooting and operating procedures of FF series sub-zero ice machines. The ice making system has a vertical, static evaporator with a rotating auger. The machine is equipped with a solid state PC board, which controls and monitors the functionality of the ice machine, indicating:

- (1) Ice level
- (2) Water level
- (3) Motor and gearbox operation
- (4) Temperature of condenser
- (5) Level of refrigerant

II. Operation Conditions & Performance Parameters

1. Conditions for Operation of FF Scale Ice Machine

	Minimum Operating Conditions	Maximum Operating Conditions
Ambient Temperature	5°C	40°C
Water Temperature	5°C	35°C
Water Pressure	0.15MPa	0.5MPa
Deviation from Voltage Rating	-10%	+10%

2. Diagram for Ice Output of sub Zero Ice Machine

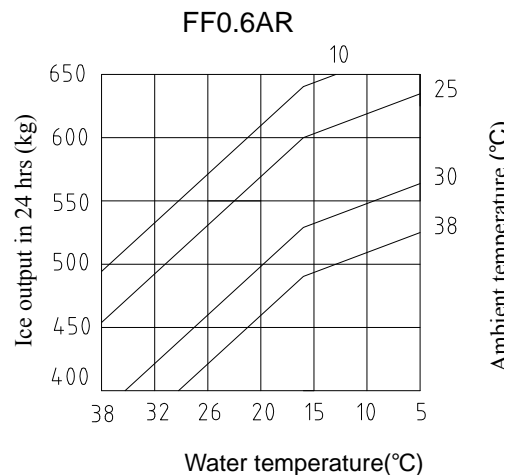
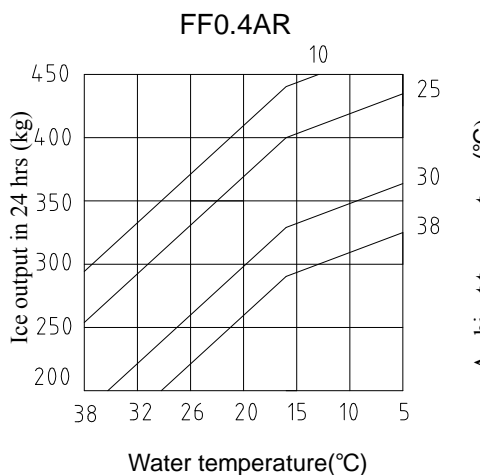

The parameters are subject to change without notice

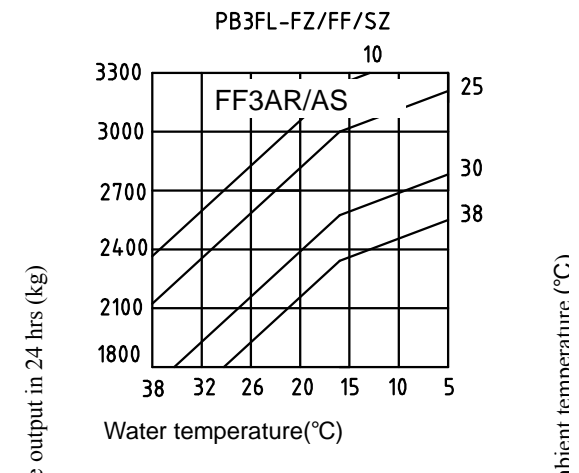
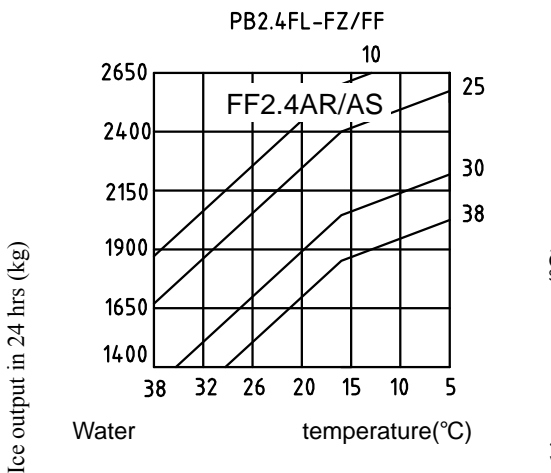
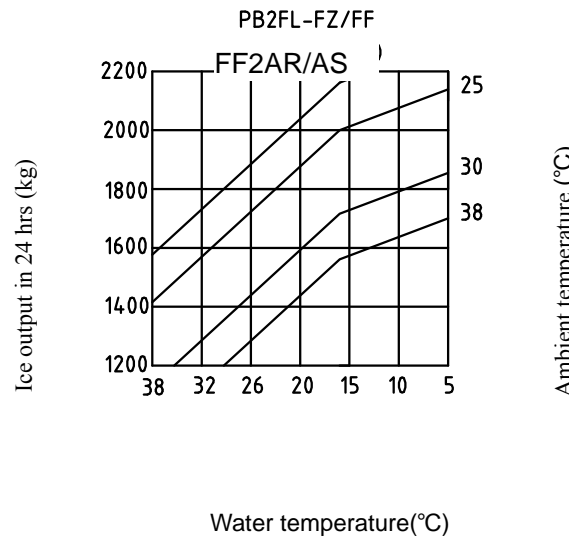
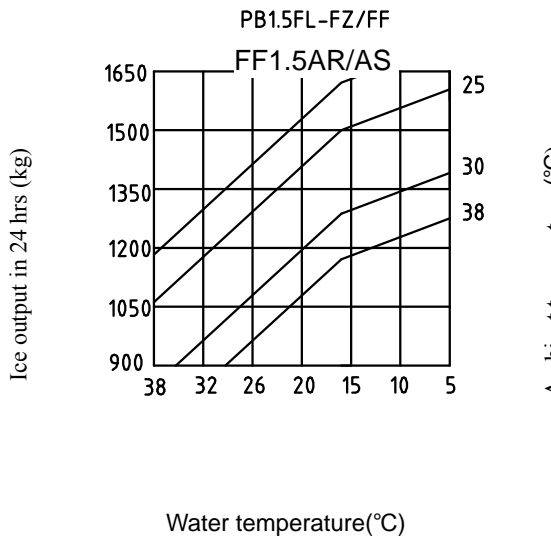
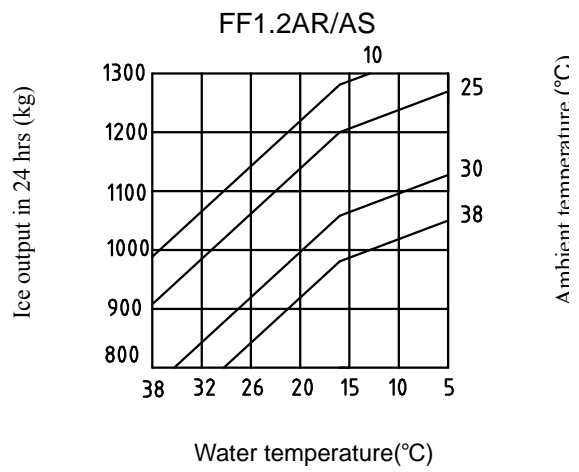
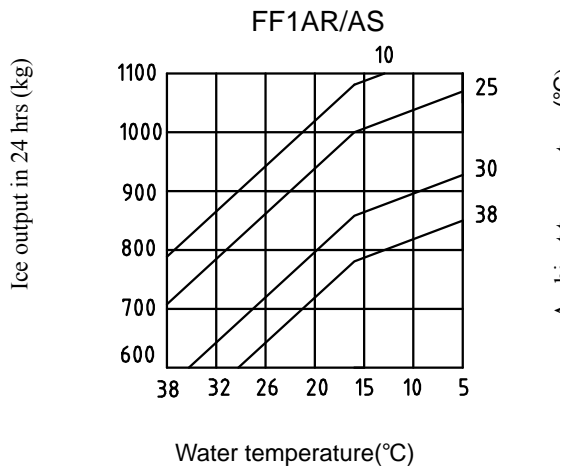

Note:

Daily ice output is directly related to the air temperature at the condenser and inlet water temperature. In order to keep optimum operation performance of FF series sub-zero ice machines maintenance must be performed on a regular basis as per service manual section V.

Model description: FFxxxAR model is a complete unit including refrigeration system ready for connection to power, water and drainage. The FFxxxAS is a split system comprising two components, low side evaporator with control system and air cooled refrigeration condensing unit. To be installed by qualified refrigeration technician only. The FFxxxWR is a complete system with water cooled condenser, ready to connect to water supply, power and drainage and condenser water (to be supplied by others).

3. Parameters of Sub Zero Ice Machine

Model	Voltage (V)	Current (A)	Condensing Type	Compressor (HP)	Power (W)	Wiring Size (mm ²)	Water usage (l/h)	Inlet pipe (outside thread)	Drain pipe (outside diameter)	Weight (kg)
FF0.4AR	230V/50Hz/1N	14.5	Air-cooled unit	2	3100	3×2.5	17	3/4"	Φ21	180
FF0.6AR	230V/50Hz/1N	18	Air-cooled unit	3	3900	3×2.5	25	3/4"	Φ21	250
FF1AR	380V/50Hz/3N	11.5	Air-cooled unit	6	3400	5×2.5	42	3/4"	Φ21	315
FF1AS	380V/50Hz/3N	11.5	Air-cooled split unit	6	3400	5×2.5	42	3/4"	Φ21	320
FF1.2AR	380V/50Hz/3N	15	Air-cooled unit	6.5	5100	5×2.5	50	3/4"	Φ21	320
FF1.2AS	380V/50Hz/3N	15	Air-cooled split unit	6.5	5100	5×2.5	50	3/4"	Φ21	325
FF1.5AR	380V/50Hz/3N	16	Air-cooled unit	8	6700	5×2.5	63	3/4"	Φ21	380
FF1.5AS	380V/50Hz/3N	16	Air-cooled split unit	8	6700	5×2.5	63	3/4"	Φ21	385
FF2AR	380V/50Hz/3N	18.5	Air-cooled unit	10	7500	5×4	85	3/4"	Φ21	470
FF2AS	380V/50Hz/3N	18.5	Air-cooled split unit	10	7500	5×4	85	3/4"	Φ21	475
FF2.4AR	380V/50Hz/3N	21	Air-cooled unit	12	9800	5×4	100	3/4"	Φ21	550
FF2.4AS	380V/50Hz/3N	21	Air-cooled split unit	12	9800	5×4	100	3/4"	Φ21	560
FF3AR	380V/50Hz/3N	23	Air-cooled unit	12	10500	5×4	125	3/4"	Φ21	590
FF3AS	380V/50Hz/3N	23	Air-cooled split unit	12	10500	5×4	125	3/4"	Φ21	595

FF3WR	380V/50Hz/3N	23	Water-cooled unit	12	10500	5×4	125	3/4"	Φ21	570
-------	--------------	----	-------------------	----	-------	-----	-----	------	-----	-----

4. Working Pressure (Ambient temperature 25°C,R404A)

Model	FF0.4AR	FF0.6AR	FF1AR/FF1AS	FF1.2AR/FF1.2AS	FF1.5AR/FF1.5AS
Discharge Pressure	1.85MPa	1.85MPa	1.85MPa	1.85MPa	1.8MPa
Suction Pressure	0.2MPa	0.2MPa	0.2MPa	0.2MPa	0.2MPa

Model	FF2AR/FF2AS	FF2.4AR/FF2.4AS	FF3AR/FF3AS	FF3WR
Discharge Pressure	1.8MPa	1.8MPa	1.65MPa	1.55MPa
Suction Pressure	0.2MPa	0.2MPa	0.2MPa	0.2MPa

5 Refrigerant Charge

Model	FF0.4AR	FF0.6AR	FF1AR	FF1AR
Refrigerant Charge (g)	2000g	3200g	4800g	5300g

Model	FF1.5AR	FF2AR	FF2.4AR	FF3AR
Refrigerant Charge (g)	6500g	10000g	11500g	15000g

Note:

This may vary if machine parameters change

6. Dimensions (See figure 1)

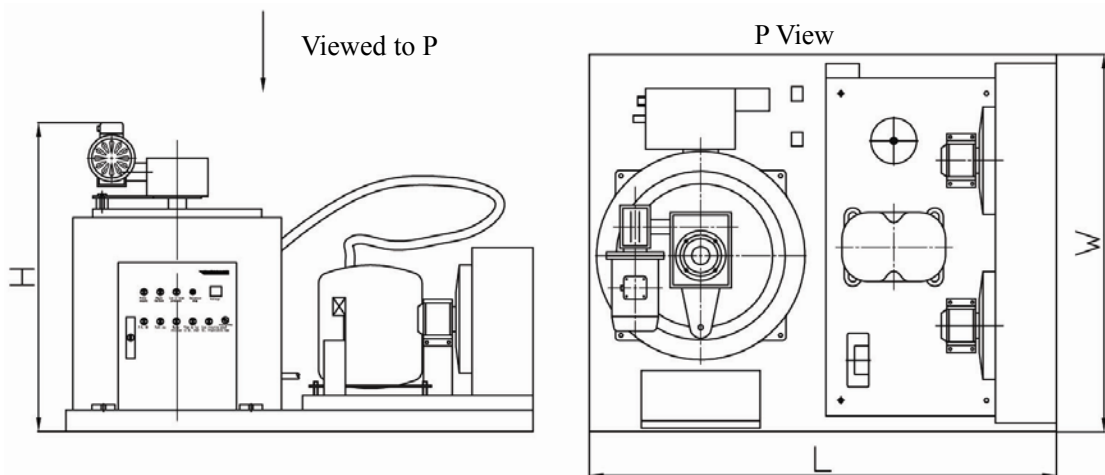

Figure 1

Model	L(mm)	W(mm)	H(mm)	condenser size for split unit (L×W×Hmm)
FF0.4AR	1100	700	720	-----
FF0.6AR	1250	750	820	-----
FF1AR	1320	1060	870	-----

FF1AS(Split unit)	1320	1060	870	1100×475×630
FF1.2AR	1320	1060	890	-----
FF1.2AS(Split unit)	1320	1060	890	1200×475×630
FF1.5AR	1320	1060	1050	-----
FF1.5AS(Split unit)	1320	1060	1050	1200×475×630
FF2AR	1620	1060	1150	-----
FF2AS(Split unit)	1620	1060	1150	1250×475×835
FF2.4AR	1620	1060	1250	-----
FF2.4AS(Split unit)	1620	1060	1250	1400×475×835
FF3AR	1620	1060	1500	-----
FF3AS(Split unit)	1620	1060	1250	1500×475×935
FF3WR(Water-cooled unit)	1620	1060	1250	-----

III. Packing/ Transportation/ Storing and Installation

- Packing, Transportation and Storing** The ice machine is packed in plywood.

Beware of collision, vibration, tilting, inversion, etc. in transportation and storage. Ice machine should be kept below 40C, dry, and well-ventilated

Before you begin:

- Check your paperwork to determine the model received matches your order.
- After uncrating and removing all packing material, inspect equipment for any shipping damage.
- Check whether all connections (water system, refrigerant system, etc.), electrical connections (wires, PC board, etc.) and mechanical system are in good condition.

2. Installation (See figure 2)

- Electrical connections must comply with local standards and requirements on the rating plate of the machine.
- An isolation switch must be installed
- Constant water supply (Pressure between 0.15 to 0.5 MPa) and stop cock shall be supplied within 1 metre of the ice machine. Suitable drainage point shall be within 1 metre of ice machine. Two separate water drainage lines shall be required for draining the ice machine and the ice storage bin.
- The ice machine shall not be placed (1) without suitable ventilation; (2) next to heat sources; or (3) outdoors.
- To ensure ice quality a water filter should be installed in icemaker inlet water line.

3. Installation Procedures

- Place the ice machine on appropriate ice storage bin and fix. See figure 2.
- Ensure machine is level
- Connect water supply with a hose.
- Connect the drains with sufficient fall.
- Open the water supply stop cock.
- Connect power to approved outlet.
- Use a qualified service technician for installation.
- See figure 3 for installation of split unit.(See figure 3)

Installation Schematic Diagram

Figure 2

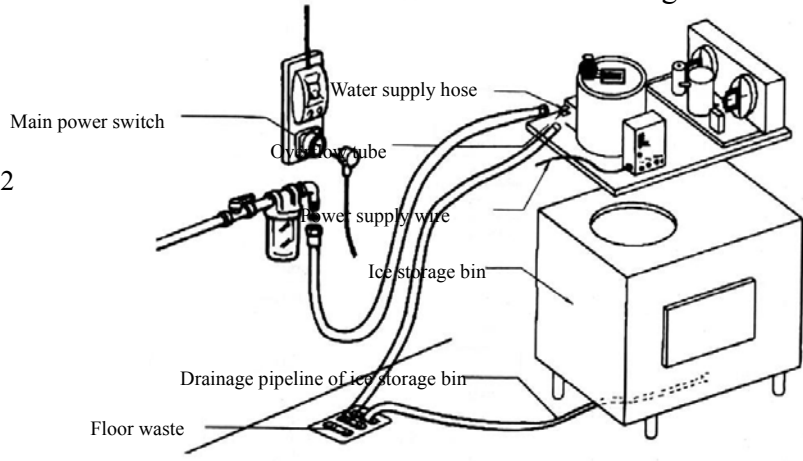

Installation Schematic Diagram for Split Unit

- 1) The unit and condenser have been charged with refrigerant;
- 2) Connect ice machine and condenser with refrigeration copper pipe. Evacuate pipe work.
- 3) Check that the joints are properly connected and there are no leaks.
- 4) Open service valves and release gas into refrigerant pipe;
- 5) The length of connecting pipeline between unit and condenser shall not be more than 8 m.
- 6) Installation by qualified refrigeration technician.

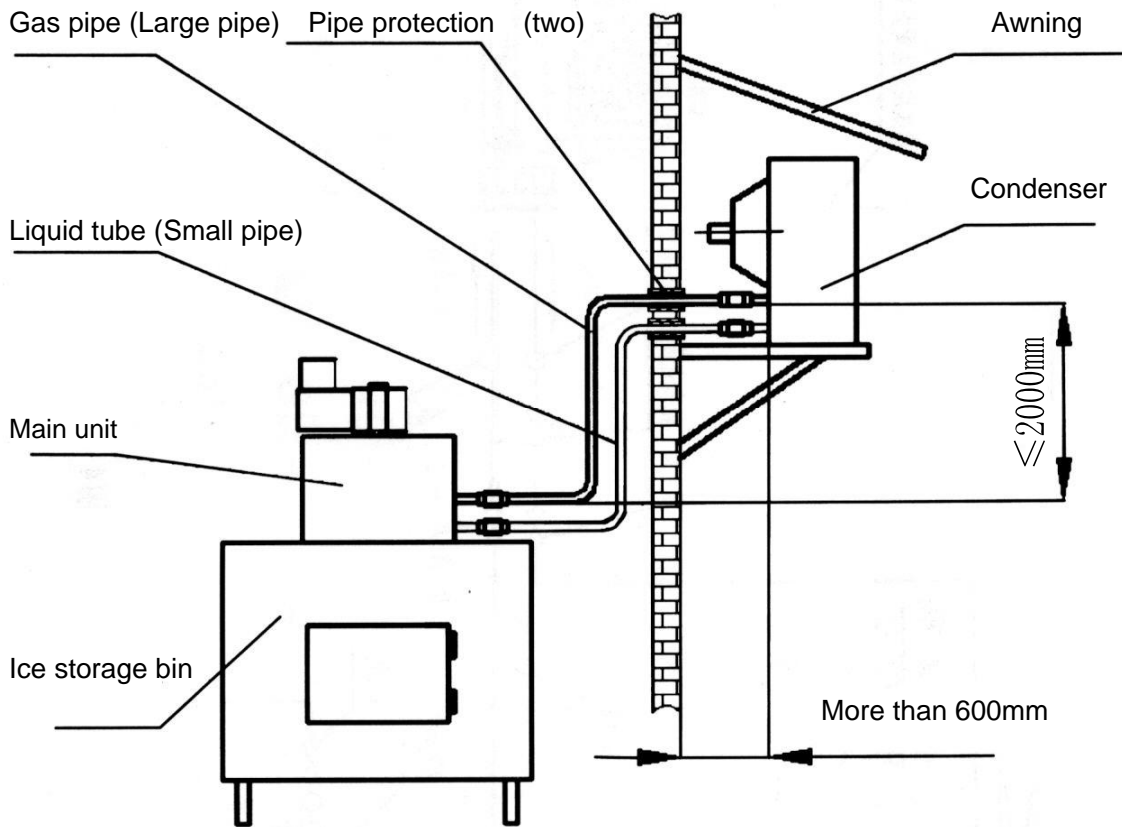

Figure 3

Operating Instructions

(1) To start up

After the machine has been installed as per instructions, plug in and switch on. The indicator light H1 (the green light) will come on. Turn the “On/Off” switch on the control box to “On” position (turn the switch in a clockwise direction) and the machine will be on 5 minutes’ delay (the fourth red light of the second row of the control box will be flashing). After 5 minutes’ delay, the machine will start.

(2) To stop the machine

Turn off the “On/Off” switch on the control box and the machine will stop. Each time you turn on the “On/Off” switch and start the machine, the machine will begin to run automatically after 5 minutes’ delay.

A. The 5 indicators lights in the second row on the front panel of the control box monitor the following:

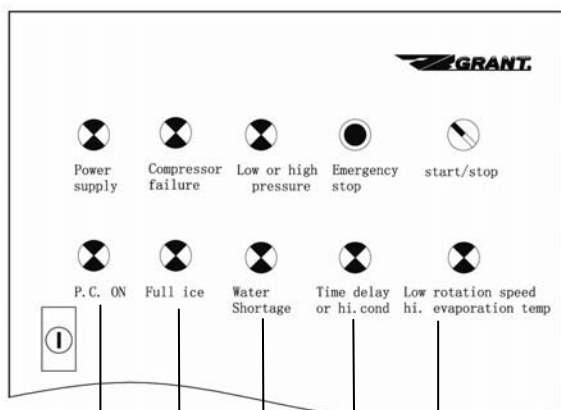

Solid red light: rotation direction of the motor is wrong, or the speed is lower than 1300 rpm.
 The red light is flashing: high evaporator temperature, i.e. the evaporating temperature fails to drop below -1°C 10 minutes after startup.
 Solid red light: condenser temperature is too high.

The red light is flashing: a 5 minutes delay status after startup (normal working status)

The yellow light is on: insufficient water in the water reservoir. The machine will resume operation automatically after supply is restored.

The yellow light is on: the storage bin is full of ice and the machine will resume its operation automatically after the ice has been removed.

The green light is on: normal operation.

Note:

- Reasons for high condenser temperature: faulty fan motor; blocked condenser; high ambient temperature; damaged condenser, faulty temperature sensor or P.C board.
- Reasons for high evaporator temperature: check refrigeration system, faulty evaporator temperature sensor or P.C board.

E. The third red light in the first row (H3) on the front panel of the control box will be on if the discharge pressure of the compressor is higher than the specified value (factory set) or if the suction pressure is lower than the specified value (factory set). Please identify causes and rectify before resetting the machine manually.

F. In event of emergency, push the “Emergency Shutdown” button to stop the machine.

IV. Operating Principles

1. Refrigerant System (See figure 5)

Refrigerant in a gas state is pumped throughout the refrigeration system by a hermetic **compressor** to the **condenser**. Heat is removed from the refrigerant either by forced air movement through an air-cooled condenser or transferring heat from the refrigerant to water through a water-cooled condenser. The refrigerant changes to a liquid when cooled. The refrigerant in a liquid state passes through a **filter drier**. The filter drier traps small amounts of moisture and foreign particles from the system. The filter drier **must** be replaced whenever the refrigeration system is opened or if the refrigerant charge has been completely lost. Refrigerant in a high-pressure liquid form is fed to an expansion valve where the refrigerant is reduced to a low-pressure liquid. Under this low pressure, the liquid will absorb heat from the evaporator causing the liquid to change to a vapor. This vapor is then drawn into the compressor where the temperature and pressure of the vapor are increased. The high temperature, high pressure vapor flows to the condenser where the heat is removed, causing the vapor to return to the liquid form, making the refrigerant ready to flow back to the evaporator to pick up more heat.

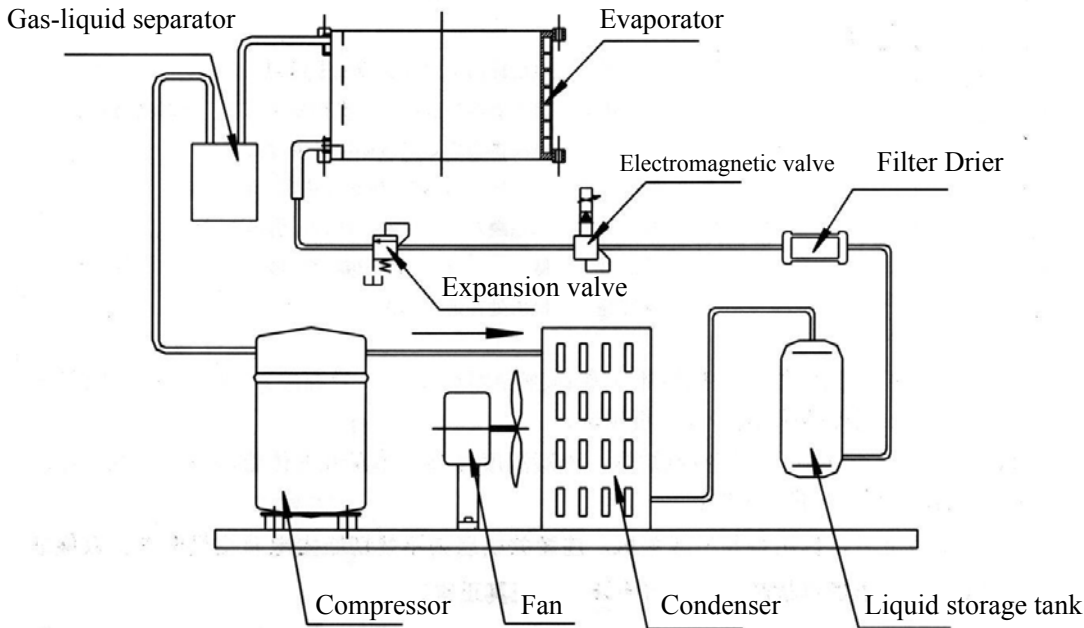

Figure 5

2. Water Circulation System (See figure 6)

Water enters the machine through the float valve and into the water reservoir. Water is then pumped to the water distributor by a water pump and then flows on to the inner surface of the evaporator. It is cooled down gradually and forms ice. The ice blades scrape the ice from the inner surface of the evaporator and it drops into the ice storage bin through the ice chute. Some of the remaining water will flow back to the water reservoir.

Note:

- Water supply is monitored by a sensor. If there is no water in the water reservoir or the water is too soft (not containing mineral substances), the P.C. board will stop the machine, and the yellow light will indicate a lack of water.
- The water level has been factory set. Do NOT adjust it. If the water level requires adjusting, this can be achieved by adjusting the valve in the water reservoir. (The correct level is 26mm from the bottom of the water distributor)

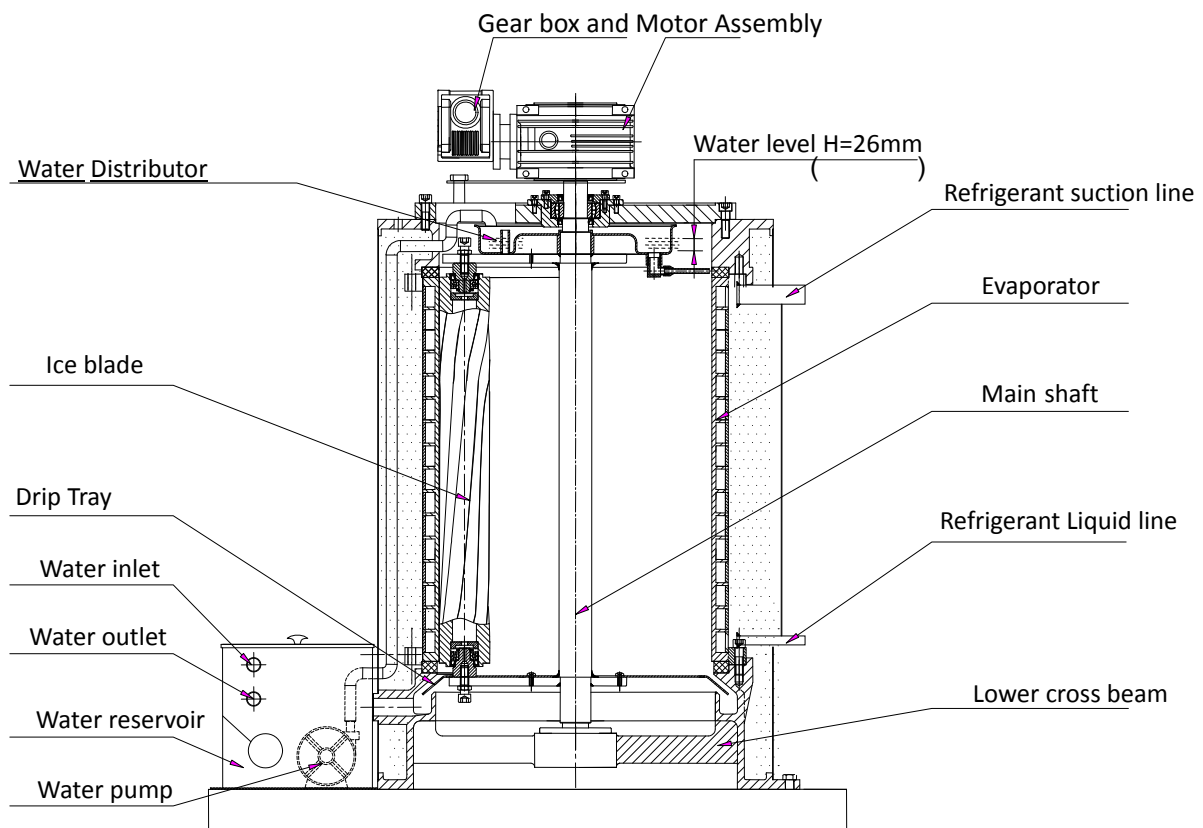

Figure 6

3. Ice Level Control System

There is a light-operated ice level controller between the machine and the ice storage bin. When the storage bin is full of ice, the ice will break the light beam of the ice level photoelectric sensor and then the red LED in the center of P.C. board will be turned off. The yellow light indicating “ice

full” will be turned on after the light beam has been broken for a continuous period of time and stops the machine. The light beam will be reset and the red light in the center of the P.C. board will be turned on if the ice is removed.

4. The Gearbox

This system includes a gear motor and gear box. The gear motor drives the gearbox. The output shaft of the gearbox drives the auger and water distributor at a speed of 2 rpm. In case of wrong rotation direction or low speed of the gear motor, the sensor will send a signal to the P.C. board, which will stop the machine. Causes of the trouble should be identified and fault should be rectified before the machine is re-started. Press the Reset key or put the On/Off switch at the "OFF" position first and then to "ON" position, the machine will begin to work again normally.

5. P.C. Board Control System (please refer to figure 7)

The P.C. board controls the whole operation of the machine according to signals sent by various sensors.

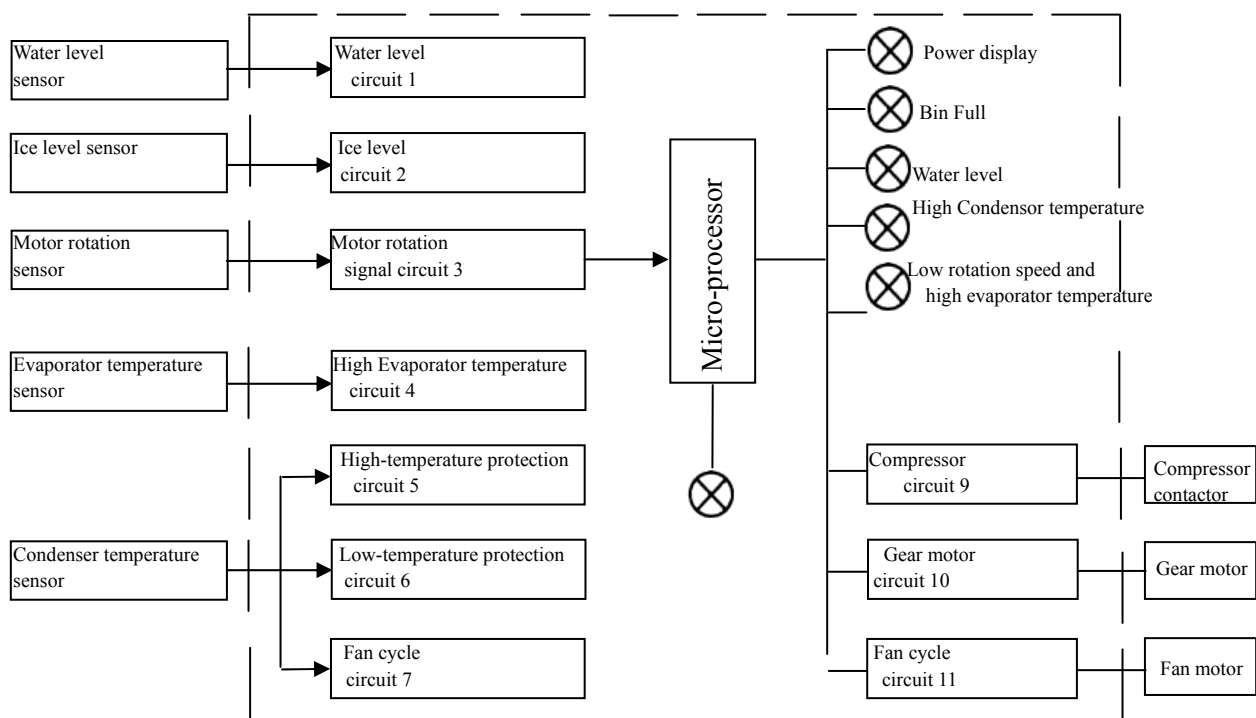
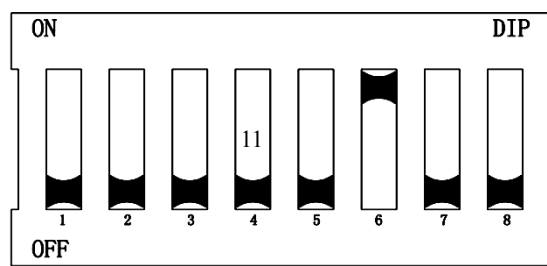

Figure 7

Notice:

There are 8 switches on the P.C. board. **Switch 1:** if it is in "ON" position there will be no 5 minutes' delay after start-up; if it is in "OFF" position there will be a 5 minute delay after start-up. The switch should be set at "OFF" position for normal operation. **Switch 3:** should be in "OFF" position. DO NOT TOUCH. **Switch 6** in the "On" position provides an audible fault alarm; (see figure 8).



V. Maintenance & Cleaning Instructions



WARNING: Ice Machine can start without warning. Disconnect power before cleaning or servicing ice machine

To ensure the quality of sub-zero flake ice make certain:

- Nothing other than ice is stored in the ice storage bin.
- Keep the bin door closed except when accessing ice.
- Ice shovel should be kept clean and sanitary

To avoid maintenance problems:

- Do not disconnect the water supply when machine is operational
- Never stack anything on the top of the ice machine.
- Do not block ventilation grills

Cleaning & Maintenance (Inhouse tasks)

Cleaning instructions below are recommended to be carried out weekly, however are subject to local water quality and environmental conditions.

- Remove ice from bin
- Mix 1 packet DeLimer Lime Scale Remover per .95lt of **HOT** water
- Clean ice storage bin
- Rinse all surfaces with clean water
- Sanitize with a preparation of KAY-5 Sanitizer solution made with luke warm water according to solution tables on packet.
- Clean the Stainless Steel thoroughly once a week, do NOT use abrasives to clean the surface.

Cleaning & Maintenance (Technician tasks)

Maintenance procedures are recommended to be carried out 6 monthly, however are subject to local water quality and environmental conditions

- Clean ice machine water system as below:

1. Remove ice from bin.
2. Mix 1 packet DeLimer Lime Scale Remover per quart (.95 L) of **hot** water. Circulate solution through machine until deposits are removed (about 30 minutes). Brush where necessary. Drain DeLimer Solution.
3. Repeat if scale remains.
4. Clean ice storage bins. Soak parts in DeLimer Solution until deposits are removed.
5. Rinse all surfaces with clean water.
6. Reassemble machine.
7. Sanitize all surfaces.
8. Make and discard 10 minutes of ice production before using.
 - Inspect Refrigeration System for faults
 - Inspect Electrical System for faults

- Clean all drains
- Check water filter and change cartridge (where applicable)
- Clean the air cooled condenser as required.

NOTE: Failure to perform the required maintenance at the frequency specified may void warranty.

2. Trouble Shooting

Problem	Possible Causes	Suggested Solutions
<p>Machine does not start</p> <p>(1) No power light</p> <p>(2) Bin full light on.</p> <p>(3) Low water light on.</p> <p>(4) Condenser temperature light on.</p> <p>(5) Low speed rotation light flashes.</p> <p>(6) Low rotation speed light is on.</p>	<p>Main switch is in OFF position. P.C. board fuse (750mA) is blown. P.C. board faulty.</p> <p>Faulty ice level control. Insufficient water.</p> <p>Condenser is blocked. Faulty fan motor. Condenser temperature sensor is damaged. Ambient temperature is too low.(Below 4°C) Insufficient refrigerant. Evaporator temperature sensor is faulty.</p> <p>Insufficient refrigerant Wrong rotation of gear motor. Low rotation speed.</p>	<p>Turn switch to ON position. Replace fuse and check the cause. Replace P.C. board.</p> <p>Clean or replace ice level control. Check water supply, replace water filter cartridge, replace water float. Clean the condenser. Replace the fan motor. Replace the sensor.</p> <p>Place the machine in the location at required room temperature. Fill with refrigerant. Replace the sensor.</p> <p>Fill with refrigerant Check the connecting wire of motor and capacitor. Check the bearings of motor and freezer cylinder.</p>
Compressor won't start	<p>No voltage, Low voltage. Overload tripped, Compressor faulty , Bin Full, Loose wires on contactor</p>	<p>Check isolator/fuses Check power, call electrician. Reset Replace compressor. Remove ice Tighten wires</p>
Low ice production.	<p>Expansion valve is partly blocked or improperly adjusted. Moisture content in the system is too high. Water level in water distributor is low. Low gas charge.</p>	<p>Adjust or evacuate. Evacuate the system again. Adjust the water level to specified level. Check for leaks and fill with refrigerant.</p>
The machine doesn't produce ice.	<p>No water in the evaporator. Gear motor stuck.</p>	<p>Water supply pipe to the evaporator blocked. Clear. Check and repair or replace it.</p>
Constant water loss to drain	<p>Water level in the water reservoir is too high. Water level in the water distributor is too high or too low.</p>	<p>Check water pressure Adjust water float. Adjust again.</p>
Gearbox noisy.	<p>Motor bearings are worn. Gearbox has a lack of lubricant. Bearings and gears in the gear case are worn out.</p>	<p>Check and replace bearing. Lubricate gearbox. Check and Replace.</p>
No water	<p>Interruption to water supply. Water filter blocked</p>	<p>Check and clean out any obstructions. Check and replace cartridge</p>
<p>Red Alarm light on.</p> <p>High discharge pressure</p> <p>Low suction pressure</p>	<p>Fan doesn't work. Solenoid valve is not open. Expansion valve is out of adjustment. Insufficient refrigerant.</p>	<p>Check or replace the fan. Check or replace the valve. Adjust the valve properly. Check for refrigerant leak, repair and recharge system.</p>

VI. Electrical Wiring Diagram of the Scale Ice Machines

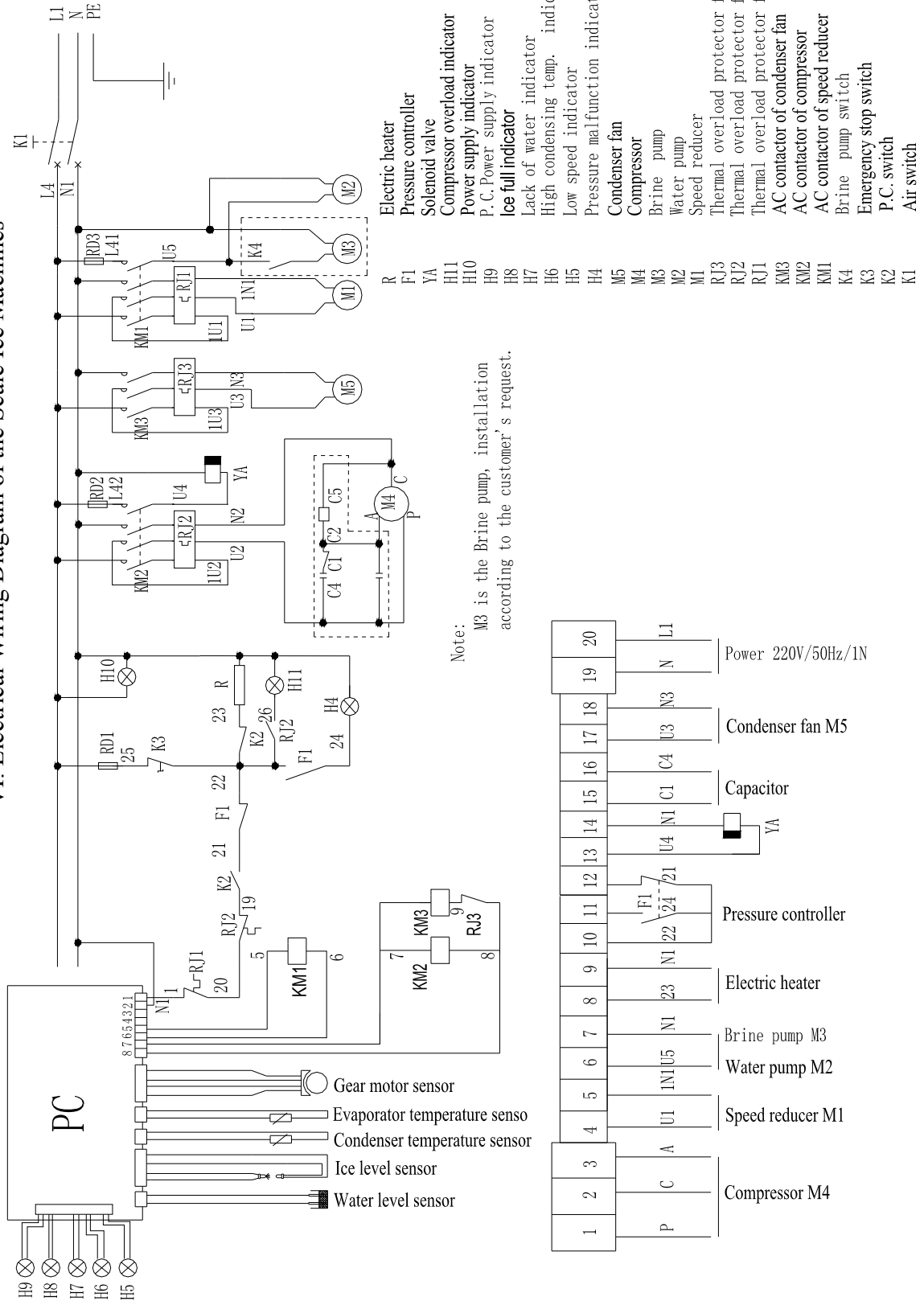

VII . Main Parts and Components Diagram of Scale Ice Machines

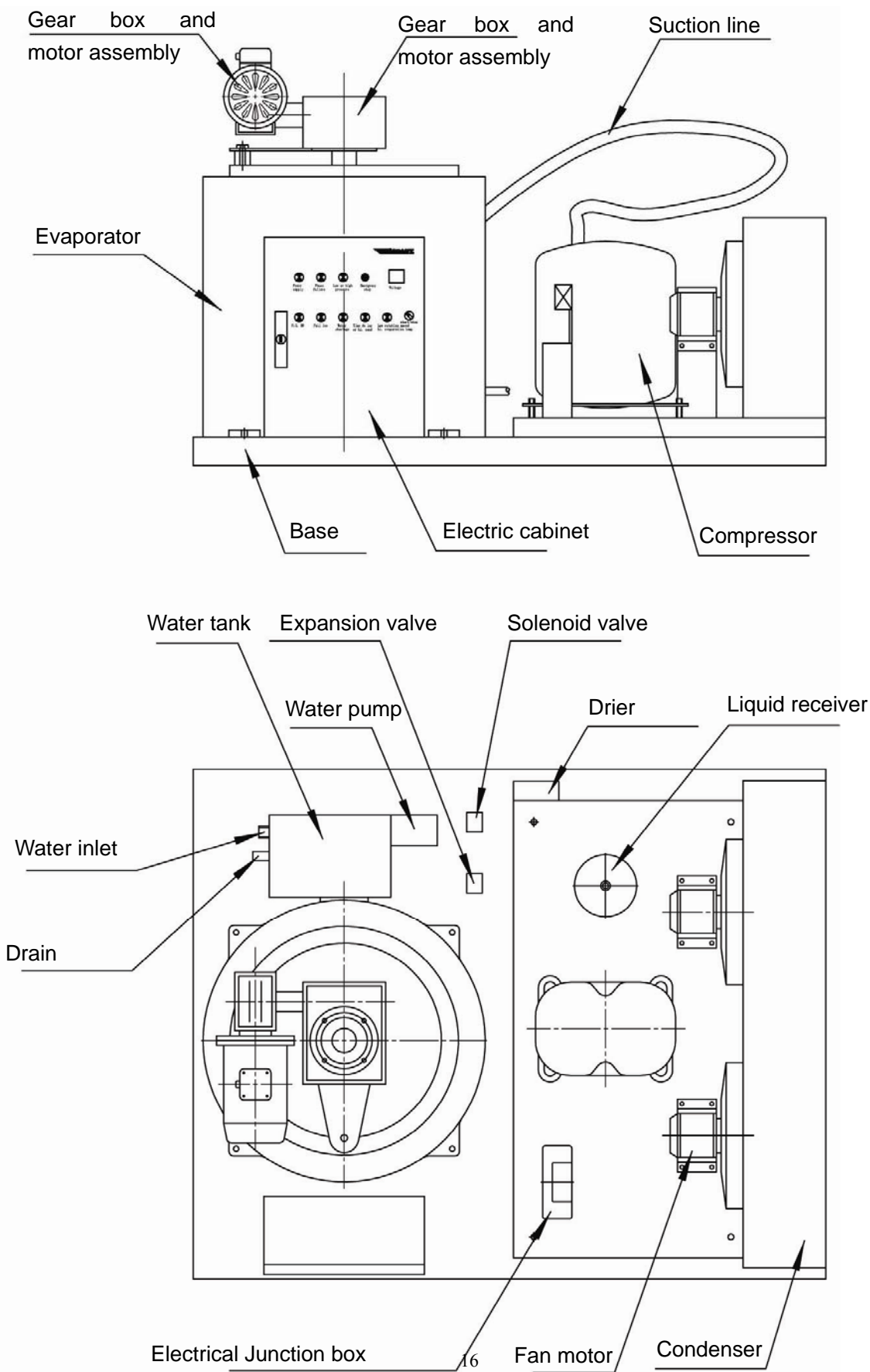

VIII P.C. Board and Sensor Assy.

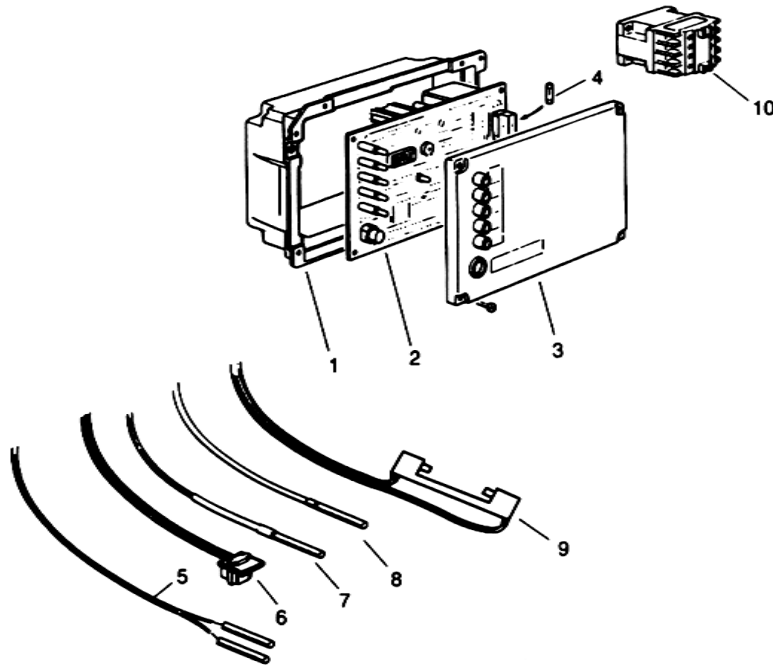

P.C. Board and Sensor Assembly.

Item No	Parts No	DESIGNATION
1	205001.00	Control Box
2	205003.00	P.C. Board Assembly.
3	205002.00	Control Box Cover
4	205004.00 205005.00	Fuse (750 mA) Fuse (10A)
5	205007.00	Water Level Sensor
6	205008.00	Rotation Speed Sensor
7	205009.00	Condenser Temperature Sensor
8	205010.00	Evaporator Temperature Sensor
9	205011.00	Ice Level Control Assembly.
10	205006.00	Contactor

Australian Distributor

Coast Distributors Pty Ltd

Unit 1, 9-11 Ethell Road

Kirrawee NSW 2232

Ph. (02) 9545 5162

Fax. (02) 9545 3490

Email. sales@coastdistributors.com.au

Web. www.coastdistributors.com.au

Manufactured By

NINGBO GRANT REFRIGERATION EQUIPMENT MANUFACTURING CO., LTD

Address (cont.): Ningbo. Zhejiang, China

Postal Code: 315153

Website address: <http://www.grant-ice.com>