

Ice-O-Matic[®]

**SERVICE
MANUAL**

ICEU045

ICEU065

ICEU085

**Cubers
with storage**

TABLE OF CONTENTS		page	
	Table of contents	2	
	Specifications ICEU045	3	
	Specifications ICEU065	5	
	Specification ICEU085	6	
	GENERAL INFORMATION AND INSTALLATION		
	Introduction	9	
	Unpacking and Inspection	9	
	Location and levelling	9	
	Electrical connections	9	
	Water supply and drain connections	10	
	Final check list	10	
	Installation practice	11	
	OPERATING INSTRUCTIONS		
	Start up		
	Operational checks	12	
		12	
	OPERATING PRINCIPLES (How it works)		
	Freezing cycle	13	
	Harvest cycle	15	
	Component description	15	
	ADJUSTMENT, REMOVAL AND REPLACEMENT PROCEDURES		
	Adjustment of the cube size control	17	
	Adjustment of the bin level control	17	
	Wiring diagram	18	
	Service diagnosis	19	
	MAINTENANCE AND CLEANING INSTRUCTIONS		
	General	21	
	Icemaker	21	
	Cleaning instructions of water system	21	

SPECIFICATIONS

CUBER MODEL ICEU045

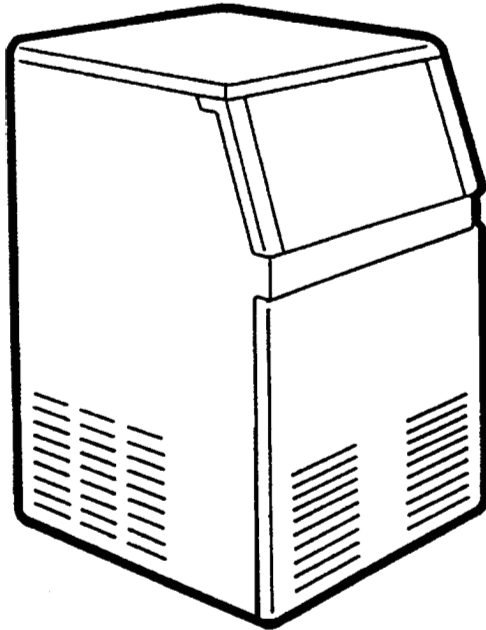

Important operating requirements:

	MIN.	MAX.
Air temperature	10°C	40°C
Water temperature	5°C	40°C
Water pressure	1 bar	5 bar
Electr. voltage variations from voltage rating specified on nameplate	-10%	+10%

ice making capacity

AIR COOLED MODELS

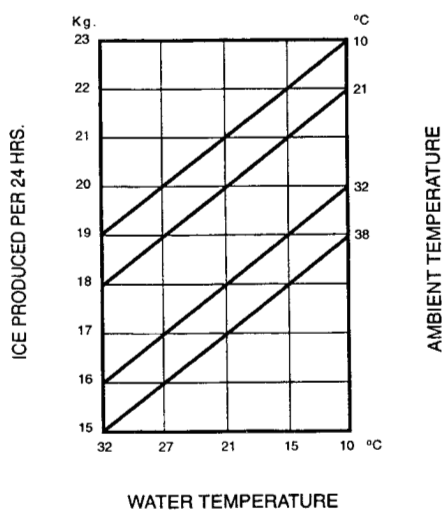

WATER COOLED MODELS

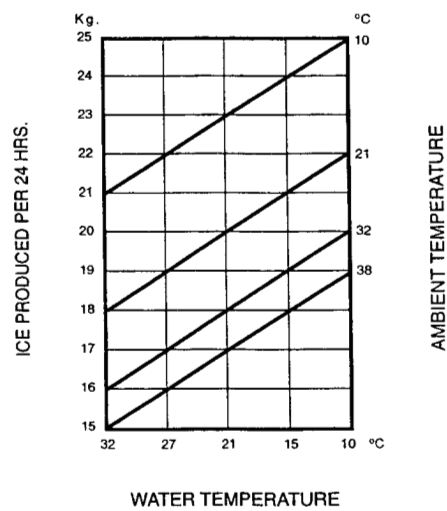

NOTE. The daily ice-making capacity is directly related to the condenser air inlet temperature, water temperature and age of the machine.
To keep your **ICE-O-MATIC CUBER** at peak performance levels, periodic maintenance checks must be carried out as indicated on page 21 of this manual.

SPECIFICATIONS

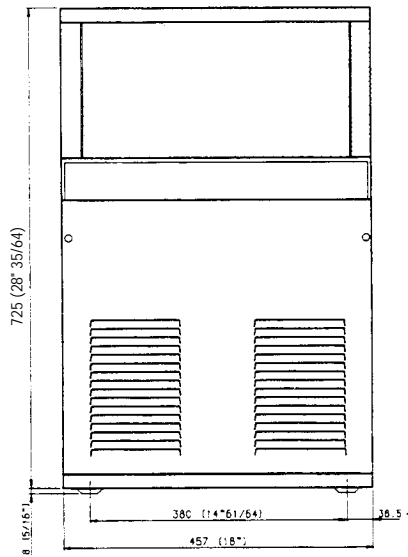
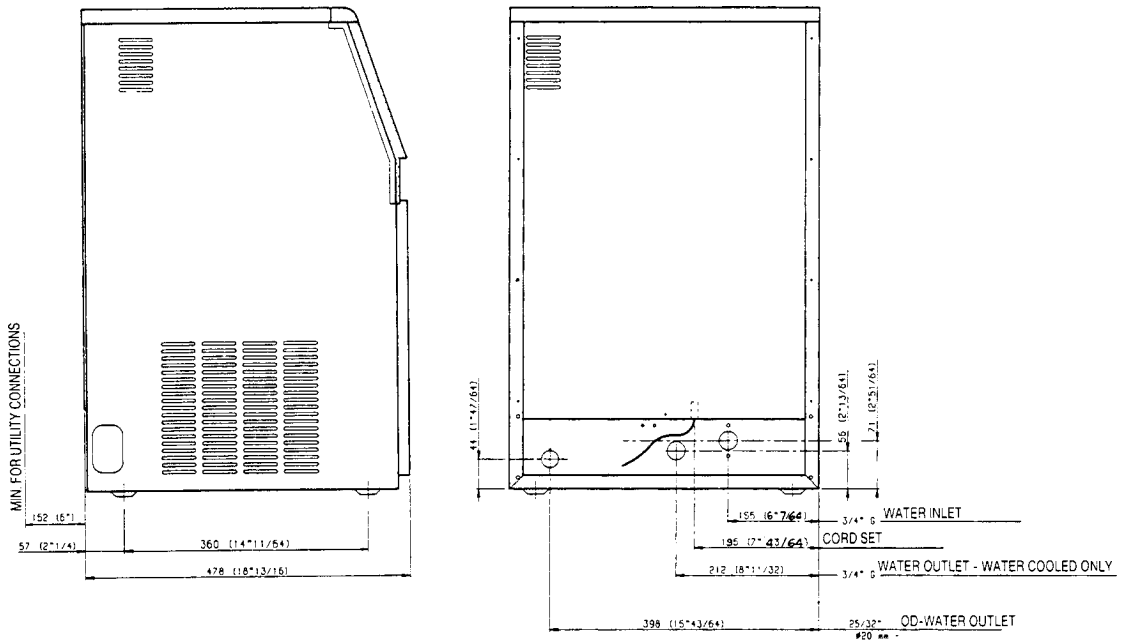

Dimensions:

HEIGHT	725 mm.
WIDTH	457 mm.
DEPTH	522 mm.
WEIGHT	39 Kgs.

**ICEU045-CUBER
machine specifications**

Model	Cond. unit	Finish	Comp. HP	Capacity the cold store	Water req. lt/24 HR
ICEU045	Air Water	Stainless steel	1/4	14 Kg.	110 290*

Basic electr.	Amps	Start Amps	Watts	Electric power cons. Kwh per 24 Hr	Nr. of wires	Amps fuse
230/50/1	2.2	11	340	6.5	3 x 1.5 mm ²	10

Cubes per harvest: 18 medium
* A 15°C water temperature

SPECIFICATIONS

CUBER MODEL ICEU065

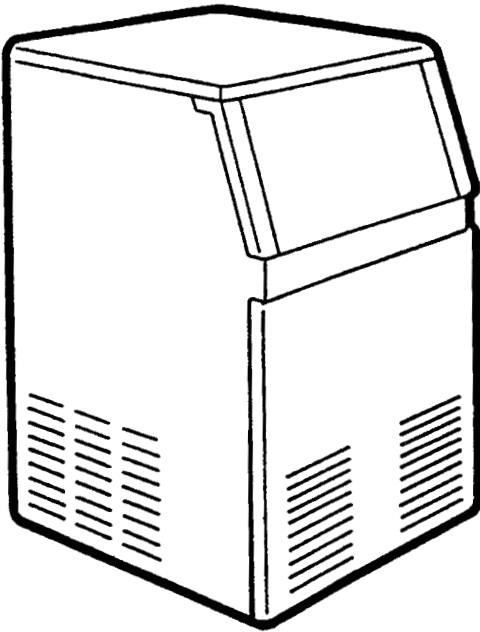

Important operating requirements:

	MIN.	MAX.
Air temperature	10°C	40°C
Water temperature	5°C	40°C
Water pressure	1 bar	5 bar
Electr. voltage variations from voltage rating specified on nameplate	-10%	+10%

ice making capacity

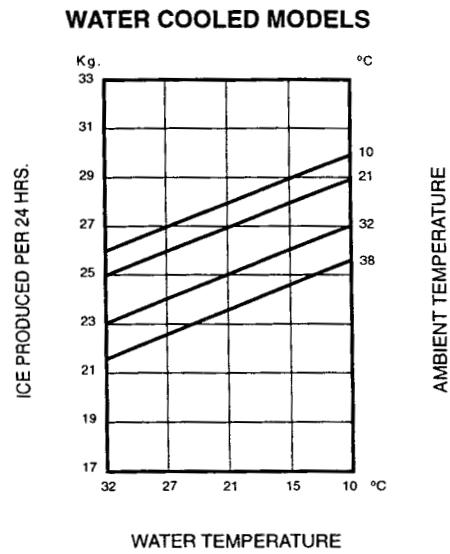
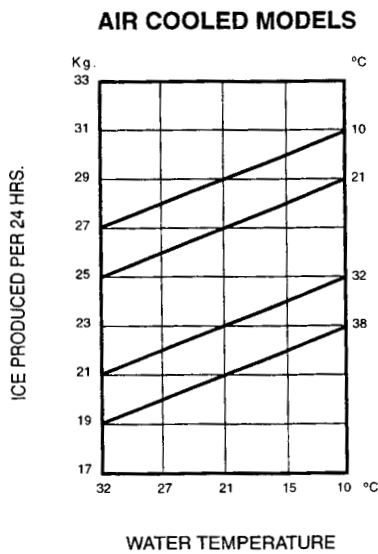

NOTE. The daily ice-making capacity is directly related to the condenser air inlet temperature, water temperature and age of the machine.
To keep your **ICE-O-MATIC CUBER** at peak performance levels, periodic maintenance checks must be carried out as indicated on page 21 of this manual.

SPECIFICATIONS

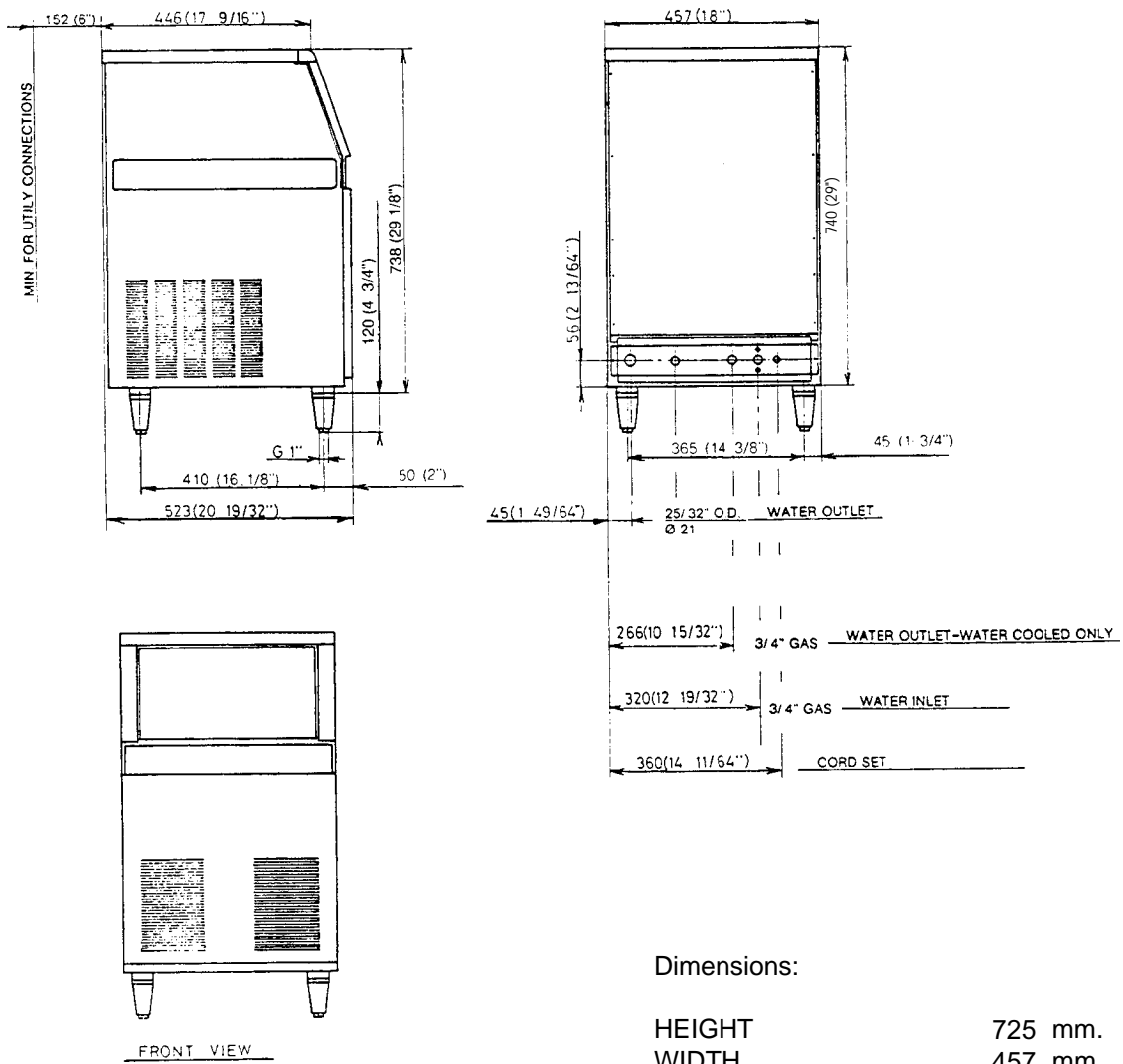

Dimensions:

HEIGHT	725 mm.
WIDTH	457 mm.
DEPTH	522 mm.
WEIGHT	41 Kgs.

**ICEU065-CUBER
machine specifications**

Model	Cond. unit	Finish	Comp. HP	Capacity the cold store	Water req. lt/24 HR	
ICEU065	Air Water	Stainless steel	1/4	14 Kg.	105 300*	
Basic electr.	Amps	Start Amps	Watts	Electric power cons. Kwh per 24 Hr	Nr. of wires	Amps fuse
230/50/1	2.4	11	360	7	3 x 1.5 mm ²	10

Cubes per harvest: 24 medium
* A 15°C water temperature

SPECIFICATIONS

CUBER MODEL ICEU085

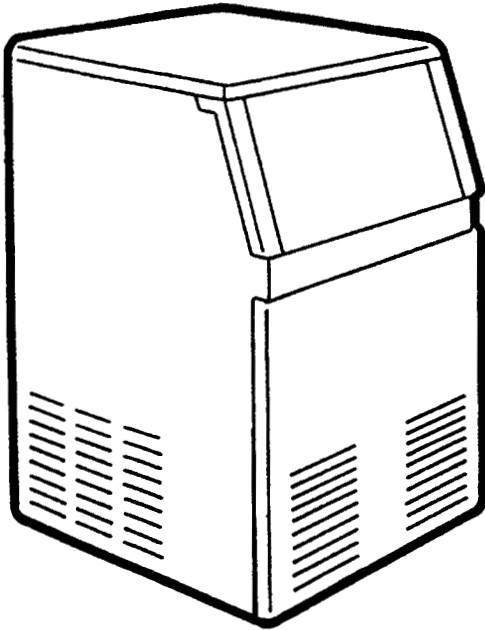

Important operating requirements:

	MIN.	MAX.
Air temperature	10°C	40°C
Water temperature	5°C	40°C
Water pressure	1 bar	5 bar
Electr. voltage variations from voltage rating specified on nameplate	-10%	+10%

ice making capacity

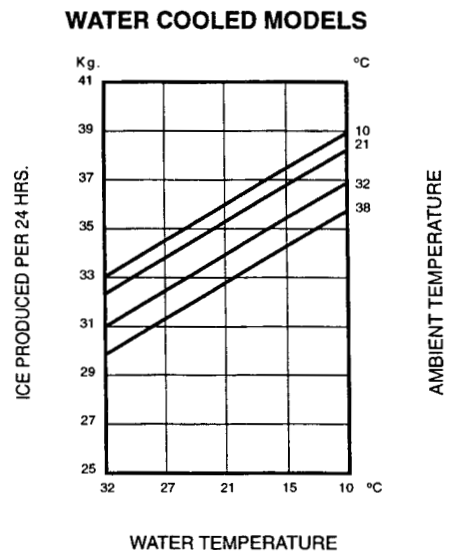
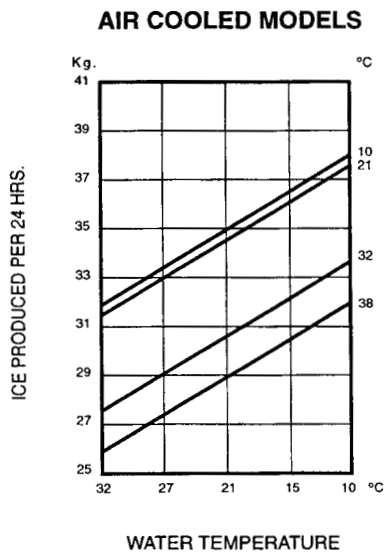

NOTE. The daily ice-making capacity is directly related to the condenser air inlet temperature, water temperature and age of the machine.
To keep your **ICE-O-MATIC CUBER** at peak performance levels, periodic maintenance checks must be carried out as indicated on page 21 of this manual.

SPECIFICATIONS

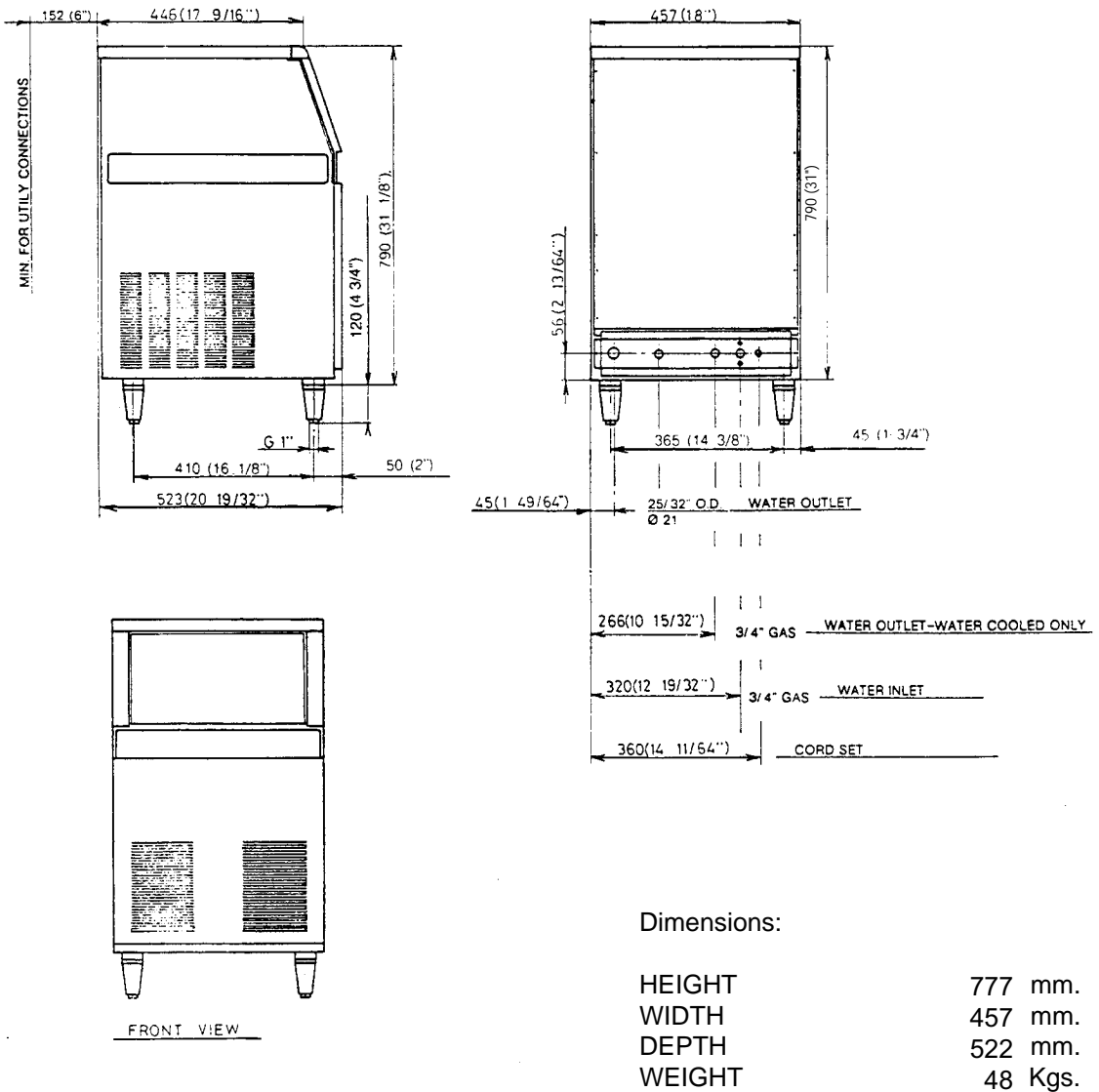

**ICEU085-CUBER
machine specifications**

Model	Cond. unit	Finish	Comp. HP	Capacity the cold store	Water req. lt/24 HR	
ICEU085	Air Water	Stainless steel	3/8	14 Kg.	140 480*	
Basic electr.	Amps	Start Amps	Watts	Electric power cons. Kwh per 24 Hr	Nr. of wires	Amps fuse
230/50/1	3.2	17	500	10	3 x 1.5 mm ²	10

Cubes per harvest: 24 medium
 * A 15°C water temperature

GENERAL INFORMATION AND INSTALLATION

A. INTRODUCTION

This manual provides the specifications and the step-by-step procedures for the installation, start-up and operation, maintenance and cleaning for the ICE-O-MATIC ICEU045, ICEU065 and ICEU085 ice makers.

The Mechanical Cubers are quality designed, engineered and manufactured.

Their ice making systems are thoroughly tested providing the utmost in flexibility to fit the needs of a particular user.

These ice makers have been engineered to our own rigid safety and performance standards.

NOTE: To retain the safety and performance built into this ice maker, it is important that installation and maintenance be conducted in the manner outlined in this manual.

UNPACKING AND INSPECTION

1. Call your authorized ICE-O-MATIC Distributor or Dealer for proper installation.
2. Visually inspect the exterior packing and skid. Any severe damage noted should be reported to the delivering carrier and a concealed damage claim form filled in, subject to inspection of the contents with the carrier's representative present.
3.
 - a) Cut and remove the plastic strip securing the carton box to the skid.
 - b) Remove the packing nails, securing the carton box to the skid.
 - c) Cut open the top of the carton and remove the polystyrene protection sheet.
 - d) Pull out the polystyrene posts from the corners and then remove the carton.
4. Remove front and rear panels of the unit and inspect for any concealed damage. Notify carrier of your claim for the concealed damages as stated in Step 2, above.
5. Remove all internal support packing and masking tape.
6. Check that refrigerant lines do not rub against or

touch other lines or surfaces, and that fan blades move freely.

7. Check that the compressor fits snugly into all its mounting pads.
8. Use clean damp cloth to wipe the surfaces inside the storage bin and the outside of the cabinet.
9. See data plate near the rear side of the unit and check that the local main voltage corresponds with the voltage specified on it.

CAUTION. Incorrect voltage supplied to the ice maker will void your parts replacement program.

10. Remove the manufacturer's card from the inside of the User Manual and fill in all parts including: Model and Serial Number taken from the data plate.

C. LOCATION AND LEVELLING

WARNING: This IceCuber is designed for indoor installation only. Extended periods of operation at temperatures exceeding the following limitations will constitute misuse under the terms of the ICE-O-MATIC Manufacturer's Limited Warranty resulting in **LOSS of warranty.**

1. Position the unit in the selected permanent location. Criteria for selection of location include:
 - a) Minimum room temperature 10°C (50°F) and a maximum room temperature 40°C (100°F).
 - b) Water inlet temperatures: minimum 5°C (40°F) and maximum 40°C (100°F).
 - c) Well ventilated location for air cooled models.
 - d) Service access: adequate space must be left for all service connections through the rear of the ice maker. A minimum clearance of 15cm(6") must be left at the sides of the unit for routing cooling air drawn into and exhausted out of the compartment to maintain proper condensing operation of air cooled models.
2. Level the unit in both the left to right and front to rear directions.

D. ELECTRICAL CONNECTIONS

See data plate for current requirements to determine wire size to be used for electrical connections. All ICE-

O-MATIC ice makers require a solid earth wire.

All ICE-O-MATIC ice machines are supplied from the factory completely pre-wired and require only an electric power point for the cord provided at the rear of the unit.

Make sure that the ice machine is connected to its own circuit and individually fused (see data plate for fuse size). The maximum allowable voltage variation should not exceed -10% and +10% of the data plate rating. Low voltage can cause malfunctioning and may be responsible for serious damage to the overload switch and motor windings.

NOTE: All external wiring should conform to national, state and local standards and regulations.

Check voltage on the line and the ice maker's data plate before connecting the unit.

E. WATER SUPPLY AND DRAIN CONNECTIONS

GENERAL

When choosing the water supply for the ice-cuber consideration should be given to:

- a) Length of run
- b) Water clarity and purity
- c) Adequate water and supply pressure.

Since water is the most important single ingredient in producing ice, it cannot emphasize too much the three items listed above. Low water pressure, below 1 bar may cause malfunction of the ice maker unit. Water containing excessive minerals will tend to produce cloudy coloured ice cubes, plus scale build up on parts of the water system.

WATER SUPPLY

Connect the 3/4" male fitting of the solenoid water inlet valve, using a food grade flexible tube or a 3/8" O.D. copper pipe, to the cold water supply line with a standard plumbing fitting and a shut off valve installed in an accessible position between the water supply line and the unit.

If water contains a high level of impurities, it is advisable to consider the use of the Water Drain Valve – or the installation of an appropriate water filter or conditioner. On the water cooled version, the water inlet solenoid

valve has two separate outlets, one for the condenser and the second for the production of ice.

WATER DRAIN

The recommended drain tube is a plastic or flexible tube with 18mm (3/4") I.D. which runs to an open trapped and vented drain. When the drain is a long run, allow 3cm pitch per metre (1/4"pitch per foot). A vent at the unit drain connection is also required for proper sump drainage.

WATER DRAIN – WATER COOLED MODELS

Connect the 3/4" male fitting of the condenser water drain, utilizing a second flexible tubing, or a 3/8" O.D. copper tubing to the open trapped and vented drain.

NOTE: The water supply and the water drain must be installed to conform with the local code. In some cases a licensed plumber and/or a plumbing permit is required.

F. FINAL CHECKLIST

1. Is the unit in a room where ambient temperatures are within a minimum of 10°C (50°F) even in winter months?
2. Is there adequate clearance around the unit for proper air circulation (75mm)?
3. Is the unit level? (IMPORTANT)
4. Have all the electrical and plumbing connections been made, and is the water supply shut-off valve open?
5. Has the voltage been tested and checked against the data plate rating?
6. Has the water pressure been checked to ensure a water pressure of at least 1 bar (14psi)?
7. Check all refrigerant lines and conduit lines to guard against vibrations and possible failure.
8. Have the bolts holding the compressor down been checked to ensure that the compressor is snugly fitted onto the mounting pads?
9. Have the bin liner and cabinet been wiped clean? Has the owner/user been given the User Manual and been instructed on the importance of periodic maintenance checks?

11. Has the Manufacturer's registration card been filled in properly? Check for correct model and serial number against the serial plate and mail the registration card to the factory.

12. Has the owner been given the name and the phone number of the authorized ICE -O-MATIC Service Agency serving him?

G. INSTALLATION PRACTICE

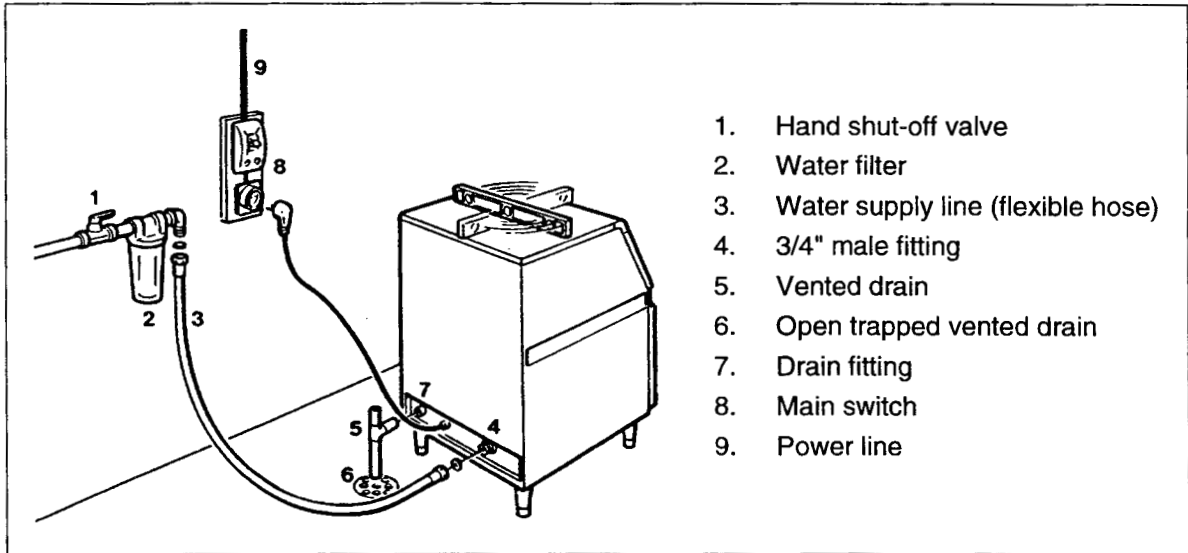

WARNING. This icemaker is not designed for outdoor installation and will not function in ambient temperatures below 10°C (50°F) or above 40°C (100°F). This icemaker will malfunction with water temperatures below 5°C (40°F) or above 40°C (100°F).

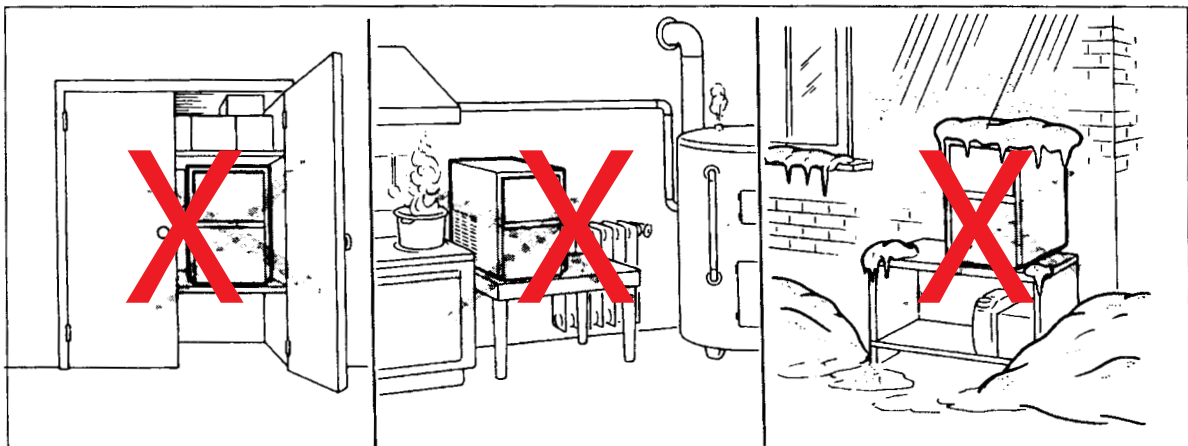

OPERATING INSTRUCTIONS

START UP

After having correctly installed the ice maker and completed the plumbing and electrical connections, perform the following "Start-Up" procedure.

1. Remove the unit front panel and locate the cleaning switch on the control box.
2. Set the cleaning switch in the cleaning position. This will close the electrical circuit to the water inlet valve and to the hot gas valve.
3. Switch on the power point. Unit will start up in defrost cycle mode. During this cycle the components energized are:

WATER INLET SOLENOID VALVE HOT GAS SOLENOID VALVE

The **water pump** and the **Fan motor** are also in operation.

4. Run unit in defrost cycle for about three/four minutes until water is coming out of the drain hose.

NOTE: During the defrost cycle, the water inlet solenoid valve is energized, the water flows through the evaporator plate and then down to fill up the icemaker sump tank for the next cycle.

OPERATIONAL CHECKS

1. The unit now starts its first freezing cycle with the following components in operation:
COMPRESSOR
WATER PUMP
FAN MOTOR in air cooled version.
2. Check to see through the ice discharge opening that the spray system is correctly seated and that the water jets uniformly reach the interior of the inverted cup molds, also make sure that the plastic curtain is hanging freely and there is not excessive water spilling through it.
3. The ice making process takes place by water being sprayed up into the evaporator cup molds; the refrigeration process removes the heat from the water causing ice formation in the cup molds.

4. When the evaporator temperature reaches a pre-set value, the evaporator thermostat or cube size control changes its contacts; the freezing cycle ends and starts the defrost or harvest cycle.

Freezing time will range between 20 and 22 minutes in a 21°C ambient temperature. Longer time for temperature above, shorter when below. Average complete cycle range is about 23-25 minutes

5. Check during the first defrost/harvest cycle, that the incoming water flows correctly into the sump reservoir in order to re-fill it and the surplus overflows through the overflow drain tube.
6. Check the texture of the ice cubes just after release. The correct size will have a small depression (about 5-6mm) in the crown.

If not, wait for the second defrost/harvest cycle before performing any adjustment.

7. If required, the length of the freezing cycle can be modified by turning the knob of the cube size control or evaporator thermostat located in front of the control box until the desired size is achieved.

If the ice cubes are shallow and cloudy, it is possible that the icemaker is running short of water during the end of the freezing cycle or, the quality of the supplied water requires the use of an appropriate water filter or conditioner.

During the defrost or harvest cycle, hold a handful of ice cubes against the bulb of the storage bin thermostat. The icemaker will switch OFF in approximately one –two minutes.

Remove the ice from the thermostat and the icemaker will restart automatically in three – four minutes.

NOTE: The bin thermostat is factory set at 1°C (35°F) OUT and 4°C (39°F) IN.

8. Re-fit the unit front panel then instruct the owner/ user on the general operation of the ice machine and about the cleaning and care it requires.

PRINCIPLE OF OPERATION

How it Works

In the ICE-O-MATIC cube ice makers, the water used to make the ice is kept constantly in circulation by a water pump which primes it to the spray system nozzles from where it is diverted into the inverted cup molds of the evaporator (Fig A). A small quantity of the sprayed water freezes into ice: the rest of it cascades by gravity into the sump assembly below for recirculation.

FREEZING CYCLE (Fig. B)

The hot gas refrigerant is discharged from the compressor and flows to the condenser coil where the heat is removed, by air being drawn through the coil by the condenser fan, the refrigerant condenses into a liquid and flows through the liquid line and filter drier and into the capillary tube.

As the liquid refrigerant leaves the capillary tube and enters the evaporator coil, a pressure drop occurs (due to the increase in pipe diameter) the liquid starts to boil and in doing so, absorbs heat from the sprayed water causing ice to form in the cup molds.

The refrigerant then increases in volume and changes entirely into vapour. The refrigerant then passes into the suction accumulator (used to prevent any small amounts of refrigerant from reaching the compressor), and through the suction line. In both the accumulator and the suction line the refrigeration exchanges heat with the capillary tube (heat exchanger), before returning to the compressor to start the cycle over.

The freezing cycle is controlled by the evaporator thermostat which has the bulb in contact with the evaporator plate. The electrical components in operation during the freezing cycle are:

COMPRESSOR
WATER PUMP
FAN MOTOR (in air cooled version)

On the air cooled versions the refrigerant head pressure is gradually reduced from a value of approx. **11 bars (155 psig)** at the beginning of the freezing cycle with the unit at 21°C (70°F) ambient temperature, to a minimum value of approx.. **7 bars (100psig)**, just at the end of the freezing cycle, a few seconds before the defrost cycle. The lowering of the pressure is related to the reduction of the evaporating temperature, caused by the progressive growth of ice in the evaporator cup molds and the flow of air through the condenser coil. The above values are in direct relation to the ambient temperatures (water and air) and are subject to rise with an increase in these temperatures.

On the water cooled versions, the refrigerant head pressure ranges between 8.5 and 10 bars (120-140psig) being controlled by an automatic hi pressure control that energizes a water solenoid valve located on the water line to the condenser, which meters the cooling water to the condenser.

At the start of the freezing cycle the refrigerant suction or lo-pressure lowers rapidly to 1.0 bar-14psig then it declines gradually – in relation to the ice thickness - to reach, at the end of the cycle, approx. 0-0.1 bar - 0-1.5 psig with the cubes fully formed in the cup molds. The total length of the freezing cycle ranges from 23-25 minutes.

DEFROST OR HARVEST CYCLE (Fig D)

When the temperature of the evaporator thermostat, in contact with the evaporator coil, drops to a pre-set value it changes its electrical contacts, energizing the following components:

COMPRESSOR
WATER INLET SOLENOID VALVE
HOT GAS SOLENOID VALVE

The incoming water, passing through the water inlet valve and the flow control, runs over the evaporator plate and then flows by gravity through the dribbler holes down into the sump reservoir (Fig C).

The water filling the sump/reservoir forces part of the surplus water from the previous freezing cycle to go out to the waste through the overflow pipe. The overflow limits the level of the sump water which will be used to produce the next batch of ice cubes. Meanwhile, the refrigerant, as hot gas discharged from the compressor, flows through the hot gas valve directly into the evaporator plate, by-passing the condenser. The hot gas circulating into the evaporator warms up the copper molds causing the harvest of the ice cubes. The ice cubes released from the cups, drop by gravity onto a slanted cube chute, then through a curtained opening they fall into the storage bin.

When the temperature of the evaporator thermostat bulb reaches the value of +3-4°C, their electrical contacts move back to the previous position, activating a new freezing cycle and de energizing both the hot gas and the water inlet valves (closed).

NOTE: The length of the defrost/harvest cycle (not adjustable) changes according to the ambient temperature (shorter for hi ambient temperature and longer for low one).

FIG. A

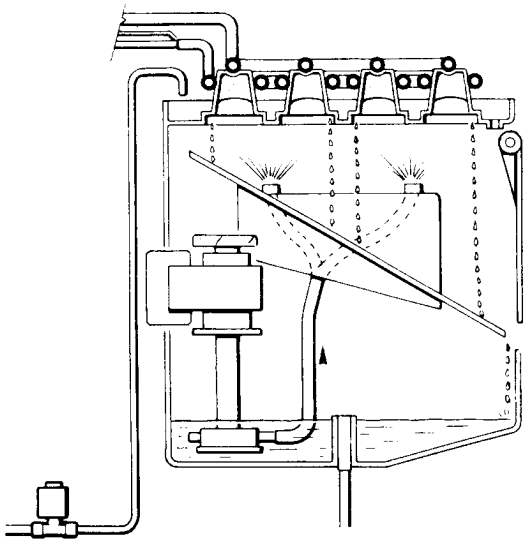

FIG. B

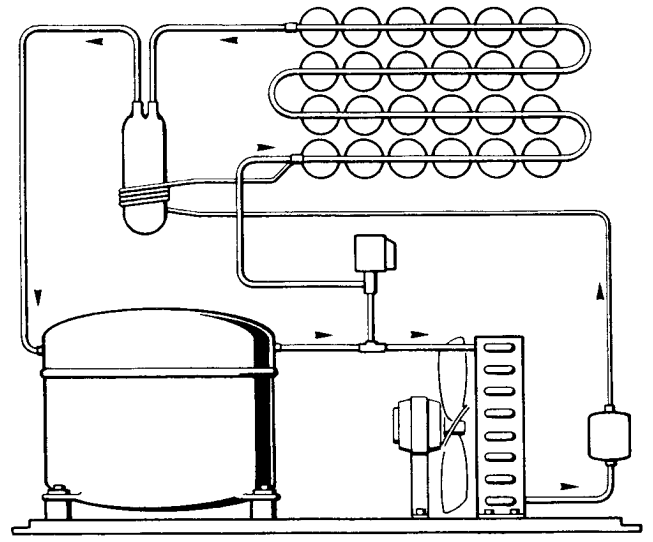

FIG. C

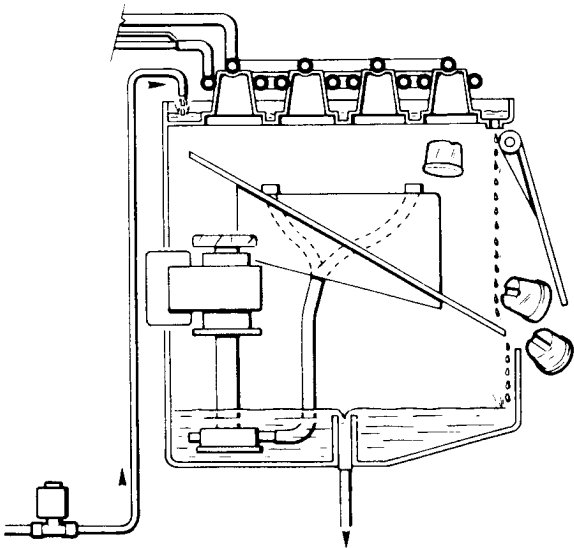
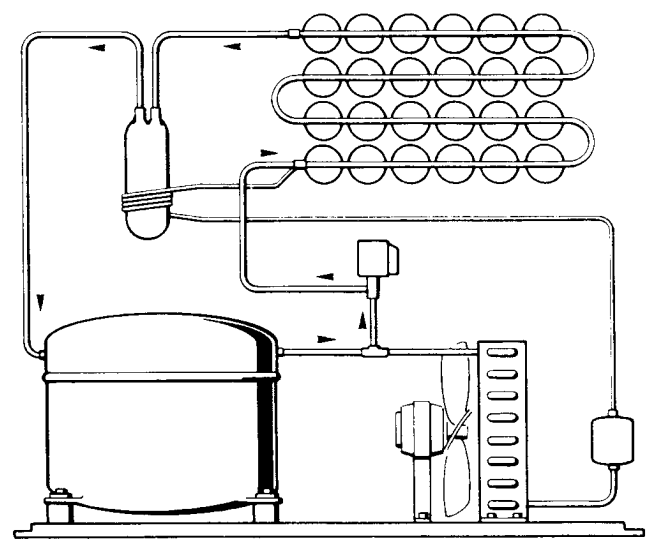

FIG. D



OPERATION – ELECTRICAL SEQUENCE

The following charts illustrate which switches and which components are ON or OFF during a particular phase of the ice making cycle. Refer to the wiring diagram for a reference.

FREEZING CYCLE **ON** **OFF**

Electrical Components

Compressor	•	
Water Pump	•	
Fan Motor (air cooler only)	•	
Hot Gas Valve		•
Inlet water valve		•

Electrical Controls **CLOSE** **OPEN**

Evaporator thermostat (contacts 3-4)	•	
Evaporator thermostat (contacts 3-2)		•
Bin thermostat	•	

HARVEST CYCLE **ON** **OFF**

Electrical Components

Compressor	•	
Water Pump		•
Fan Motor (air cooled only)		•
Hot Gas Valve	•	
Inlet Water Valve	•	

Electrical Controls **CLOSE** **OPEN**

Evaporator thermostat (contacts 3-4)		•
Evaporator thermostat (contacts 3-2)	•	
Bin thermostat	•	

Freeze Cycle

Average Discharge Pressure	
A/C:	7 - 11 bars (100 - 155 psig)
Average Discharge Pressure	
W/C:	8.5 - 10 bars (120 - 140 psig)
Suction Pressure	
End Freeze Cycle:	0 - 0.1 bar (0 - 1.5 psig)

REFRIGERANT METERING DEVICE:

Capillary tube

REFRIGERANT CHARGE (R134A)

Model	Air Cooled	Water Cooled
ICEU045	250gr (9.0oz)	250gr (9.0oz)
ICEU065	280gr (10.0oz)	250gr (9.0oz)
ICEU085	290gr (10.2oz)	250gr (9.0oz)

COMPONENTS DESCRIPTION

A. WATER PUMP

The water pump operates continually throughout the freezing cycle. The pump primes the water from the sump to the spray system and through the spray nozzles, sprays it into the inverted cup molds to be frozen into crystal clear ice cubes. It is recommended that the pump motor bearings be checked at least every six months.

B. WATER INLET SOLENOID VALVE - ¾ MALE FITTING

The water inlet solenoid valve is energized only during the defrost cycle. When energized it allows a metered amount of incoming water to flow over the evaporator cavity to assist the hot gas in defrosting the ice cubes. The water running over the evaporator cavity drops by gravity, through the dribbler holes of the plate, into the sump reservoir.

On water cooled versions the water inlet solenoid valve has one inlet and two outlets with two separate solenoids energized by the contacts 3-2 of the evaporator thermostat and the second (water cooled condenser by a specific hi pressure control.

C. HOT GAS SOLENOID VALVE

The hot gas solenoid valve consists basically of two parts - The valve body and the valve coil. Located on the hot gas line, this valve is energized by the contacts 3-2 of the evaporator thermostat during the defrost cycle.

During the defrost cycle the hot gas valve is activated, hot gas is discharged directly into the evaporator plate to defrost the formed ice cubes.

D. BIN THERMOSTAT

The bin thermostat control body is located in the front of control box behind the louvered panel. The thermostat sensing tube is located in a bulb holder on the side wall of the storage bin, where it automatically shuts the icemaker OFF when in contact with the ice and restarts the icemaker when the ice is removed. Factory settings are 1°C (35°F) OUT and 4°C (39°F) IN.

E. CUBE SIZE CONTROL (EVAPORATOR THERMOSTAT)

The cube size control (evaporator thermostat) body is located in the front of control box behind the front louvered panel; it's basically a reverse acting temperature control which closes the contacts 3-2 when its tem-

perature decreases and closes the opposite contacts 3-4 when the temperature rises.

The thermostat sensing bulb is located in a plastic tube (bulb holder) secured by two clips directly to the evaporator plate.

This control determines the length of the freezing cycle and correspondingly the size of the cubes. A lower setting will produce a larger cube (over-size) while a higher setting a smaller cube. (shallow size).

When closed on contacts 3-2 it activates the defrost or harvest cycle components.

The cube size control is set up in the factory (knob in the black dot position) and doesn't require any adjustment when the ambient temperature remains between 10°C and 32°C (50°F and 90°F)

F. FAN MOTOR (air cooled version)

The fan motor is electrically connected in parallel to the water pump and it operates continuously only during the freezing cycle keeping the proper head pressure by circulating air through the condenser fins.

G. COMPRESSOR

The hermetic compressor is the heart of the refrigerant system and it is used to circulate and retrieve the refrigerant throughout the entire system. It compresses the low pressure refrigerant vapor causing its temperature to rise and become high pressure hot vapor (hot gas) which is then released through the discharge valve.

H. WATER SPRAY SYSTEM

Through its nozzle it sprays the water in each individual cup to be frozen into ice.

I. SAFETY HI TEMPERATURE THERMOSTAT

Located on the bottom part of the control box, there is a manual reset switch that trips OFF the operation of the machine when the bulb (located on the liquid line just before the drier) reaches the temperature of 80°C (175°F)

J. CLEANING SWITCH

Located on the bottom left side of the control box, it is used to energize the water inlet and hot gas valves to charge the water into the sump tank of the machine.

ADJUSTMENT PROCEDURES

A. ADJUSTMENT OF THE CUBE SIZE CONTROL

CAUTION. Before performing actual adjustment of the cube size control, check other possible causes for cube size problems, refer to section IV, service diagnosis for problem review and analysis.

Adjustment of the cube size control is performed:

A. If ice cubes are shallow size (Indentation is too deep):

1. Locate the cube size control knob in the front of control box.
2. Rotate the adjusting knob one eighth of a turn clockwise.
3. Observe size of ice cubes in next two ice cube harvest and repeat step 2 above, in one-eighth turn increments, until proper ice cube size is achieved.

B. If ice cubes are oversize (Indentation is too full) or they are not released:

1. Locate the cube size control knob in the front of control box.
2. Rotate the adjusting knob one eighth of a turn counterclockwise.
3. Observe size of ice cubes in next two ice cube harvest and repeat step 2 above, in one-eighth turn increments, until proper ice cube size is achieved.

Once the control knob is set to obtain the ice cubes in the proper shape, the ice maker does not require any more immediate attention.

2. ADJUSTMENT OF THE BIN LEVEL CONTROL

Adjustment of the bin level control is normally performed to increase or decrease the ice level in the bin. Adjust only a maximum of one-eighth turn of the control knob at a time. Clockwise rotation corresponds to a colder setting and counter clockwise rotation corresponds to a warmer setting.

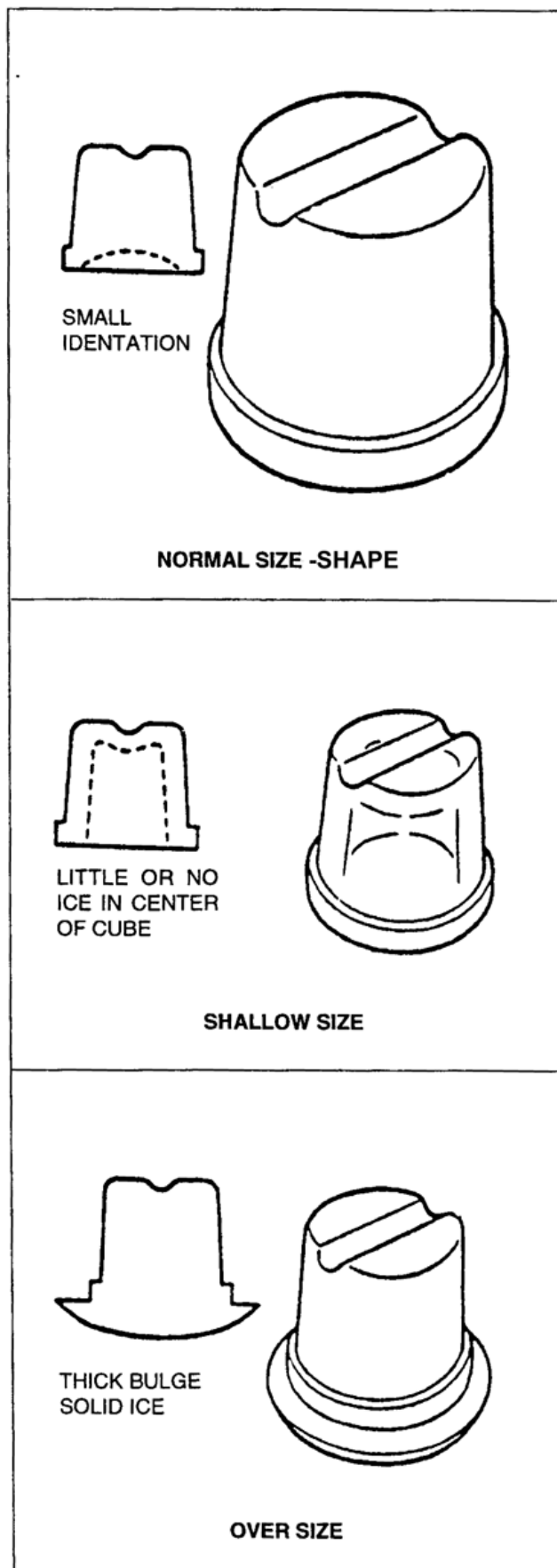

WIRING DIAGRAM

ICEU-045 - ICEU-065 - ICEU-085 - AIR AND WATER COOLED - 230/50-60/1

The unit is shown on freezing cycle

- B - WHITE
- N - BLACK
- A - BLUE
- M - BROWN
- GV - YELLOW GREEN

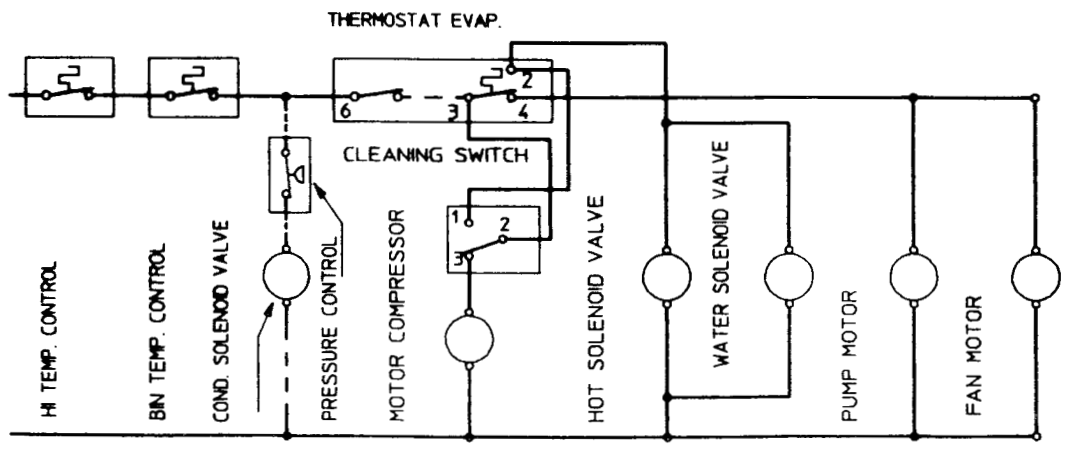
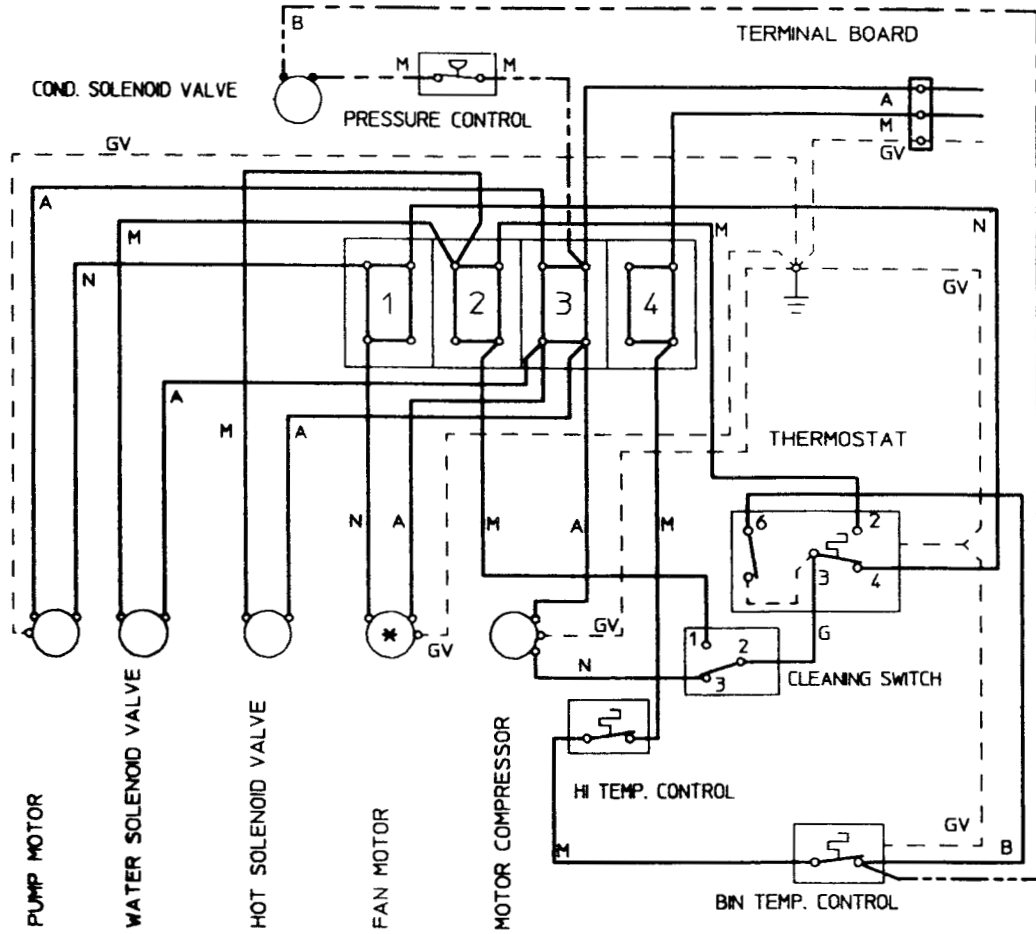

----- JUST FOR WATER COOLED UNIT

* JUST FOR AIR COOLED UNIT

05367-00 MOD 0

SERVICE DIAGNOSIS

SYMPTON	POSSIBLE CAUSE	SUGGESTED CORRECTION
Unit will not run	Blown fuse Main switch in OFF position Bin thermostat set improperly Loose electrical connections Safety thermostat in open position	Replace fuse & check for cause of blown fuse Turn switch to ON position Adjust by rotating its setting screw Check wiring Reset thermostat and check for cut out reason
Compressor cycles intermittently	Low voltage Non-condensable gas in system Dirty condenser Air circulation blocked Compressor starting device with loose wires	Check circuit for overloading Check voltage at the supply to the building. If low, contact the power company Purge the system Clean with vacuum cleaner, air or stiff brush. (DO NOT use wire brush) Allow sufficient air space all around unit. Check for loose wires in starting device
Cubes too small	Cube size control set improperly Capillary tube partially restricted Moisture in the system Shortage of water Shortage of refrigerant	Check and adjust for proper operation. Blow charge, add new gas & drier, after evacuating system with vacuum pump Same as above See remedies for shortage of water Check for leaks & recharge
Cloudy cubes	Shortage of water Dirty water supply Accumulated impurities	See remedies for shortage of water Use water softner or water filter Use ICE-O-MATIC ice machine cleaner
Shortage of water	Water spilling out through curtain Water solenoid valve not opening Water leak in sump area Water flow control plugged	Check or replace curtain Replace valve Locate and repair Remove and clean
Unit will not run	Blown fuse	Replace fuse and check for cause of blown fuse.

SERVICE DIAGNOSIS

SYMPTON	POSSIBLE CAUSE	SUGGESTED CORRECTION
Irregular cube size & some cloudy	jets blocked Shortage of water Unit not levelled	Remove jet cover and clean See shortage of water Level as required
Cubes too large	Cube size control set improperly	Check and adjust for proper operation
Decreased ice capacity	Inefficient compressor Leaky water valve Non-condensable gas in system Poor air circulation or excessive hot location Overcharge of refrigerant Capillary tube partially restricted Undercharge of refrigerant Discharge head pressure too high	Replace Repair or replace Purge the system Relocate the unit or provide for more ventilation Correct the charge. Purge off slowly Blow charge, add new gas & drier, after evacuating system with vacuum pump Charge to data plate indication See incorrect discharge pressure
Poor harvest	Restriction in incoming water line Too short defrost time Cube size control set for too large cubes Water inlet valve not opening Hot gas valve orifice restricted Air vented holes in mold cups blocked Discharge head pressure too low	Check water valve strainer and flow control. If necessary enlarge the flow control orifice Check temperature control. Replace if necessary Re-set cube size control Valve coil with open winding Replace valve Replace hot gas valve assy Clean out holes See incorrect discharge pressure
Unit won't harvest	Inoperative cube size control Hot gas valve not opening Water solenoid valve not opening	Replace cube size control Valve coil with open winding Replace valve Valve coil with open winding Replace valve
Incorrect discharge pressure	Inoperative fan motor (Air cooled) Dirty condenser Inoperative hi press control (Water cooled) Water inlet valve to condenser clogged or inoperative	Replace Clean Replace Clean or replace
Excessive water in unit base	Water tubing leaking	Check. Tighten or replace

MAINTENANCE AND CLEANING INSTRUCTIONS

A. GENERAL

The periods and the procedures for maintenance and cleaning are given as guides and are not to be construed as absolute or invariable.

Cleaning, especially, will vary depending upon local water and ambient conditions and the ice volume produced; and, each icemaker must be maintained individually, in accordance with its particular location requirements.

B. ICEMAKER

The following maintenance should be scheduled at least two times per year on these icemakers.

1. Check and clean the water line strainer.
2. Check that the icemaker is levelled in side to side and in front to rear directions.
3. Clean the water system, the evaporator, the bin and spray plates using a solution of ICE O MATIC Ice Machine Cleaner. Refer to procedure C cleaning instructions.

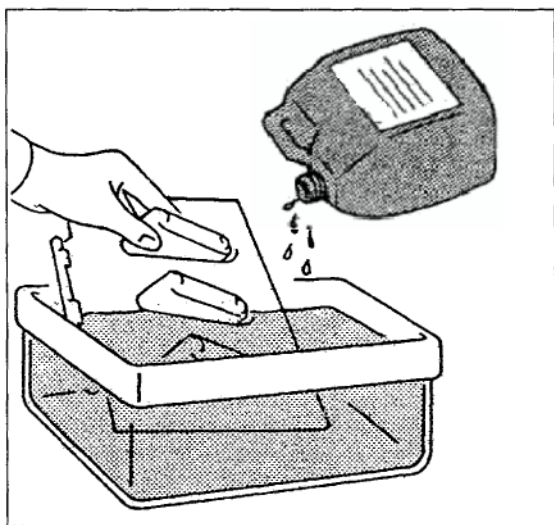

NOTE: Cleaning requirements may vary according to the local water conditions and individual user operation. Continuous check of the clarity of ice cubes and visual inspection of the water spraying parts before and after cleaning will indicate frequency and procedure to be followed in local areas.

4. With the ice machine OFF on air cooled models, clean condenser procedure C cleaning instructions using vacuum cleaner, whisk broom, or non metallic brush.
5. Check for water leaks and tighten drain line connections. Pour water down bin drain line to be sure

that drain line is open and clear.

6. Check size, condition and texture of ice cubes. Perform adjustment of Cube Size control as required.
7. Check the bin thermostat to test shut off. Place a handful of ice cubes in contact with the bin thermostat bulb for at least one minute. This should cause the icemaker to shut off. Within a few seconds of the removal of the ice from bin thermostat bulb, the icemaker restarts.

NOTE: Within minutes after the ice is removed from the bulb holder tube, the sensing bulb inside the tube will warm up and cause the icemaker to restart, This control is factory set and should not be reset until testing is performed.

8. Check for refrigerant leaks.

C. CLEANING INSTRUCTIONS FOR WATER SYSTEM

1. Remove the front and top panels to gain access to the control box and to the evaporator.
2. Make sure that all the ice cubes have been released from their cups, then rotate the cube size control knob – located on the front control box – counter-clockwise to switch off the unit.
3. Prepare the cleaning solution by diluting in a plastic container one-two litres of warm water (45-50°C) with a 0.1 - 0.2 litres of ICE O MATIC Ice Machine Cleaner.

WARNING: The ICE O MATIC Ice Machine Cleaner contains Phosphoric and Hydroxyacetic acids. These compounds are corrosive and may cause burns if swallowed. DO NOT induce vomiting. Give large amounts of water or milk. Call Doctor immediately. In case of external contact flush with water. KEEP OUT OF REACH OF CHILDREN.

4. Scoop out all the ice cubes stored in the bin in order to prevent them from being contaminated with the cleaning solution then flush out the water from the sump reservoir by removing the overflow stand-pipe.
5. Remove the evaporator cover then slowly pour the cleaning solution onto the evaporator plate. Use a brush to dissolve the most resistant stains and remove scale deposits in the plate.
6. Rotate the cube size control knob clockwise to the normal operating position (black dot) to start the

icemaking process.

7. Allow the icemaker to operate for about 20 minutes. Then turn the cleaning toggle switch to the "cleaning position" till the release of the ice cubes from their cups.

NOTE: The amount of ICE O MATIC cleaner and the time needed for the cleaning of water system depends on the water conditions.

8. Turn the cube size control knob counterclockwise to the OFF position to shut off the ice maker then flush out the cleaning solution from the sump reservoir. Pour 2 or 3 litres of clean potable water onto the evaporator cavity, to rinse the mold cups and the plates. If necessary remove the water spray plate to clean it separately as per step 3 of paragraph B.
9. Return the cube size control knob to the normal operating position (black dot). The water pump will begin operation to circulate the water in order to rinse the entire water system.
10. Do the operation as per steps 8 and 9 twice, to be sure no more traces of descaling solution remain into the sump.
11. Pour some fresh water onto the upper side of the evaporator plate, then turn the machine to normal operating mode to sanitise all the water system for approx 10 minutes.

NOTE: Do not mix the descaling with disinfectant solution. This could generate a very aggressive acid.

12. Flush out the disinfectant solution from the sump reservoir then with the switch in "cleaning" position, turn the cube size control to the normal operating position.
13. When the water starts overflowing through the drain line, set the switch to "operation" position. The unit is now ready to resume normal operation.
14. Replace the evaporator cover and the unit service panels.
15. At completion of the freezing and harvest cycle, ensure proper texture and clarity of the ice cubes and that they do not have any acid taste.

ATTENTION: If the ice cubes are cloudy/white or have an acid taste. Discard immediately.

16. Wipe clean and rinse the inner surfaces of the storage bin.

REMEMBER: To prevent the accumulation of undesirable bacteria, it is necessary to sanitize the interior of the storage bin with an anti-algae disinfectant solution weekly.

Australian Distributor

Coast Distributors Pty Ltd
Unit 1, 9-11 Ethell Road
Kirrawee NSW 2232

Ph. (02) 9545 5162

Fax. (02) 9545 3490

Email. sales@coastdistributors.com.au

Web. www.coastdistributors.com.au

Made in China.

No. 85 Yangchuan Road
Jiading Industrial Area
Shanghai, China 201821