



Symphony Plus™ ice and water dispenser

C/E 25 & 50 CI series countertop with Chewblet® ice machine

Features

11.4 or 22.7 kg (25 or 50 lb) ice storage capacity

Counter-height removable air-cooled ice machine with up to 186 kg (410 lb) daily production of popular Chewblet ice

- modular ice machine slides out from behind lower front panel
- soft, chewable, compressed nugget ice is preferred over cubes¹ and is ideal for patient care

New - Quiet Night™ sleep mode turns off ice machine when idle

Designed with sanitation in mind

New - automatic self-flushing of ice machine removes impurities

New - drain cup provides internal air gap for added protection of food zone components from drain line contaminants

- Agion® silver-based antimicrobial provides protection of key ice and water contact components²

- one-hand lever or SensorSAFE infrared ice dispense

Dependable design, easy to service and clean

New - cleaning and sanitizing of entire machine takes only 1 hour

New - LED control board provides at-a-glance machine status

- panels are easily removed for accessibility to all components

- ice machine parts are common across all Symphony Plus dispensers

- stainless steel evaporator and auger deliver long life

Environmentally responsible

- R404a refrigerant has zero ozone depletion potential

- continuous ice making process uses less electricity and water

Durable, attractive dispenser

- frame and exterior cabinet are stainless steel with accent trim

- poly drain pan, grille and dispenser lid are corrosion-resistant

- secured top lid

Easy installation and industry's best warranty

- comes fully assembled and installs with three easy connections – electric, water and drain

- warranty – 3 years parts and labor, 5 years compressor parts³

SensorSAFE™ infrared dispense option



SensorSAFE not recommended for use with clear containers or for applications in direct sunlight

Ice and water dispensers				
Ice storage capacity	Dispense	Ice machine cooling	Voltage V/Hz	Item number
11.4 kg (25 lb)	Lever	air	220/60	C25CI425A-L
	Lever	air	230/50	E25CI425A-L
	SensorSAFE	air	220/60	C25CI425A-S
	SensorSAFE	air	230/50	E25CI425A-S
22.7 kg (50 lb)	Lever	air	220/60	C50CI425A-L
	Lever	air	230/50	E50CI425A-L
	SensorSAFE	air	220/60	C50CI425A-S
	SensorSAFE	air	230/50	E50CI425A-S

Ice-only available, add -I
Example: E25CI425A-LI

Ice production		
Temperatures air/water	21/10 C (70/50 F)	32/21 C (90/70 F)
Air-cooled	186.1 kg (410 lb)	140.7 kg (310 lb)
Energy consumption per 45.4 kg (100 lb) ice	N/A	6.0 kWh air-cooled
Water consumption	45.4 L (12.0 gal) of potable water per 45.4 kg (100 lb) of ice	

Accessories

Base stand with or without factory installed water filter (refer to form# 7010)

10.16 cm (4.00") leg kit (item# 00188417)

Pressurized water sanitizing kits (refer to form# 6830)

SafeCLEAN Plus™, 3 x 7 oz packets (item# 01054683)

Water filters (refer to form# 6380, 9905, 6070)

Additional Symphony Plus accessories (refer to price list)

Job _____
Item _____

Follett Europe Polska Sp. z o.o.
Mokry Dwór 26C 83-021 Wiślnia, Poland
+48 (58) 785-6140 | Fax: +48 (58) 785-6159
folletteurope.com

801 Church Lane | Easton, PA 18040, USA
1.610.252.7301 | Fax: +1.610.250.0696 | follettice.com

FOLLETT®
Innovative solutions, inspired by ice

Specification

Ice storage capacity	25 Series – 11.4 kg (25 lb) 50 Series – 22.7 kg (50 lb)
W1 Width, dispenser	53.3 cm (21.00")
W2 Width, base stand accessory	57.8 cm (22.75")
D1 Depth, entire dispenser	61.0 cm (24.00")
D2 Depth, drain pan	17.78 cm (7.00")
D3 Depth, base stand accessory	61.9 cm (24.38")
H1 Height	25 Series – 91.4 cm (36.00") 50 Series – 101.6 cm (40.00")
H2 Dispense height clearance	26.7 cm (10.50")
H3 Height, base stand	83.8 cm (33.00")
Ventilation clearance	7.62 cm (3.00") all sides
Service clearance	30.5 cm (12.00") top, 15.24 cm (6.00") left side
Utility connection location	back or bottom
C1 220 V/60/1 ("C" models) / 230 V/50/1 ("E" models) electrical	5.5 amps, 0.8 kW 2.4 m (8') cord only
C2 Potable water inlet	3/8" FPT
C3 Drain	3/4" MPT
Heat rejection	5000 BTU/hr
Air temperature	10 - 38 C (50 - 100 F)
Water temperature	7 - 32 C (45 - 90 F)
Potable water pressure	69 - 483 kpa (10 - 70 psi)
Approximate ship weight	103 kg (226 lb)
Approximate ship weight, base stand accessory	50 kg (110 lb)

NOTE: For indoor use only

SHORT FORM SPECIFICATION: (Choose one) ___ Ice and water or ___ ice-only dispenser to be Follett® automatic load in countertop configuration, with ___ 11.4 kg (25 lb) or ___ 22.7 kg (50 lb) of storage. Environmentally responsible R404a ice machine removable for cleaning and maintenance. Dispenser frame and cabinet stainless steel with plastic trim. Ice machine to produce approximately 186 kg (410 lb) of Chewblet compressed nugget ice at air temperature of 21 C (70 F), water temperature of 10 C (50 F). Ice machine equipped with automatic self-flushing and Quiet Night sleep mode. Dispenser to have automatic bin level control to start and stop ice machine. Storage area insulated with non-CFC, high density, foamed-in-place polyurethane. 2.4 m (8') cord only. 230 V dispensers CE listed.

Dimensional drawing

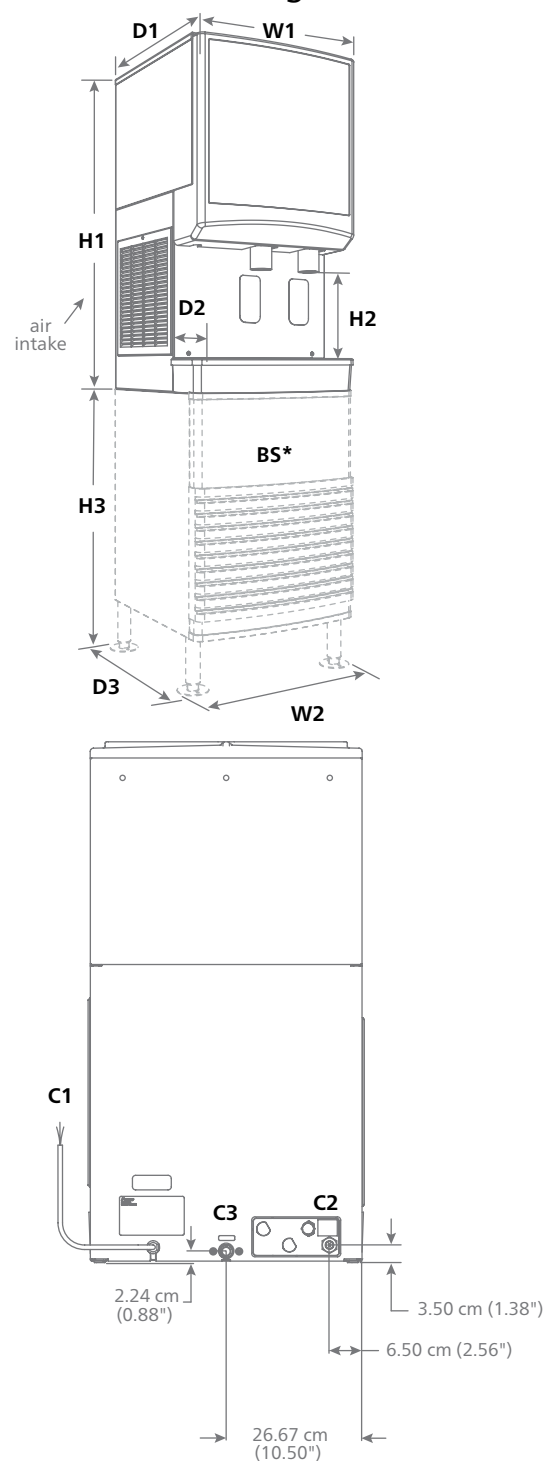

BS* – Base stand sold separately; measurements shown are with base stand legs at lowest position.

See dispenser detail sheet, form# 6675, for counter cut outs.

- 1 Independent third party studies. Contact Follett for details.
 - 2 Disclaimer: Antimicrobial protection is limited to the treated components and does not treat water or ice.
 - 3 Refer to price list for additional warranty information.
- Agion is a registered trademark of Sciessent LLC.
Symphony Plus, SensorSAFE, SafeCLEAN and Quiet Night are trademarks of Follett LLC.
Chewblet and Follett are registered trademarks of Follett LLC, registered in the US.
Follett reserves the right to change specifications at any time without obligation. Certifications may vary depending on country of origin.

C/E 25/50 CI series countertop

Form #7090 04/17
© Follett LLC



Follett Europe Polska Sp. z o.o.
Mokry Dwór 26C 83-021 Wiślina, Poland
+48 (58) 785-6140 | Fax: +48 (58) 785-6159
folletteurope.com

801 Church Lane | Easton, PA 18040, USA
1.610.252.7301 | Fax: +1.610.250.0696 | follettice.com

FOLLETT[®]
Innovative solutions, inspired by ice