



# Horizon Elite™

self-contained 710 series Chewblet® ice machine

## Features

### Horizon Elite

- 710 series - up to 759 lb (345 kg) in 24 hours
  - automatically transport ice through a tube with RIDE® technology from up to 75' (22.9 m) away
  - chewable, compressed nugget ice is preferred over cubes<sup>1</sup>
  - Chewblet ice dispenses reliably from ice and beverage dispensers
  - available with approximately 1.00" (2.54 cm) long standard Chewblet ice or optional 3/8" (0.95 cm) long Micro Chewblet™ ice
  - quiet production without noisy harvest cycles

### Revolutionary, scale inhibiting design

- produces ice that has 15% the TDS of the incoming water for optimum dispensing and long life in drinks
- quarantines and regularly expels scale producing dissolved solids to dramatically reduce scale buildup
- increases time between descaling and reduces or eliminates the need for expensive scale treatment
- saves 35% water compared to comparable cubers
- HCD and HMD models ENERGY STAR® certified

### Durable, attractive ice machine

- regular bearing inspection or replacement is not required
- upgraded, easy-to-read LED operating status and diagnostic display

### Designed with sanitation in mind

- Agion® silver-based antimicrobial product protection of key ice and water contact components<sup>2</sup>
- floatless, sealed design inhibits formation of biofilms
- semi-automatic cleaning and sanitizing system

### Warranty

- 3 years parts and labor, 5 years compressor parts<sup>3</sup>

### Certifications



<sup>1</sup> Independent third party studies. Contact Follett for details.

<sup>2</sup> Disclaimer: Antimicrobial protection is limited to the treated components and does not treat water or ice.

<sup>3</sup> Refer to price list for additional warranty information.

## Short form specification:

Ice machine to be a Follett® Horizon Elite ice machine model \_\_\_\_\_ [Insert size/series, condenser type and installation/mounting, from model number guide] capable of producing compressed nugget ice using an efficient, sanitary horizontal evaporator/auger system and delivering ice by a flexible wire reinforced transport tube to □ ice storage bin, □ ice and water dispenser, □ ice and beverage dispenser or □ drop-in dispenser and provided with a stainless steel frame and exterior, slide-out compressor/condenser with utility docking station, front-mounted unit status display, automatic self-flush, and semi-automatic cleaning and sanitizing system, plus all the features listed below and mounting/performance-enhancing accessories checked.

Model configurations				
For use with <sup>1</sup>	Install/mount	Condenser	V/Hz/Ph	Item number <sup>4</sup>
ice storage bin	top mount	air	115/60/1	HCD710ABT
			230/50/1	HCE710ABT
	RIDE	air	115/60/1	HCD710ABS
			230/50/1	HCE710ABS
Follett Vision™ undercounter ice and beverage dispenser	RIDE	air	115/60/1	HCD710AVS
			230/50/1	HCE710AVS
Cornelius PR150 undercounter ice and beverage dispenser <sup>2</sup>	RIDE	air	115/60/1	HCD710APS
countertop ice and beverage dispenser (by others)	top mount <sup>3</sup>	air	115/60/1	HCD710AHT
			230/50/1	HCE710AHT
	RIDE	air	115/60/1	HCD710AHS
			230/50/1	HCE710AHS
drop-in dispenser (by others)	RIDE	air	115/60/1	HCD710AJS
			230/50/1	HCE710AJS

<sup>1</sup> Ordered separately  
<sup>2</sup> Not compatible with Micro Chewblet ice  
<sup>3</sup> Requires top kit (see page 4)  
<sup>4</sup> For Micro Chewblet ice, replace second character (C) with an M e.g. HMD710ABT

## Accessories

- Top kit for ice and beverage dispensers (page 4)
- Water filters (refer to form# 9905)
- Wall mount bracket (item# 00997098)
- Ice machine stand, height-adjustable (item# 00997080)
- Timer to control one or two ice machines (item# 00967625)
- Longer ice transport tube, specify length: \_\_\_ ft/m in 5' / 1.5 m increments (10' / 3 m provided as standard for RIDE models) (item# 00174896)
- SafeCLEAN Plus™ ice machine cleaner
  - 1 x 8 oz (237 ml) bottle (item# 01147826)
  - 6 x 8 oz (237 ml) bottles (item# 01149954)
  - Carton of 24 x 8 oz (237 ml) bottles (item# 01149962)
- SaniSponge™, 24 sanitary sponges (item# 01075431)

## Specification

<b>W1</b> Width	22.70" (57.7 cm) Fits on 22.00" wide dispensers
<b>D1</b> Depth	24.50" (62.2 cm)
<b>H1</b> Height	21.25" (54.0 cm)
Clearance	top mount – 1.00" (2.54 cm) RIDE – See page 5-6 for details
<b>C1</b> Electrical	11.3 amps, requires dedicated 115 V/60/1 – HCD and HMD models 15 amp circuit, 6' (1.8 m) cord, NEMA 5-15 plug
<b>C2</b> Electrical	6.0 amps, requires dedicated 15 amp circuit, 6.5' (2 m) cord only. 230 V/50/1 – HCE and HME models
Operating power	0.7 kW
<b>C3</b> Ice transport tube	see page 8 for details
<b>C4</b> Water inlet	3/8" OD push-in water inlet
<b>C5</b> Drain	3/4" MPT, 1" drain required see page 7 for details
<b>C6</b> Ice bin signal cord	for Vision applications only
Air temperature	50 - 100 F (10 - 38 C)
Water temperature	45 - 90 F (7 - 32 C)
Potable water pressure	10 - 70 psi (69 - 483 kPa)
Ice production	see ice production chart on page 8
Energy consumption	4.78 kWh per 100 lb (45.4 kg) ice 90 F (32 C) air, 70 F (21 C) water
Heat rejection	8,500 BTU/hr (2,143 Kcal/hr)
Water consumption	12 gal (45.4 L) of potable water per 100 lb (45.4 kg) of ice (per AHRI test standards). 14.7 gal (47.3 L) including periodic flushing.
Refrigerant	R404A – HCD and HMD models R449A – HCE and HME models
Approximate ship weight	190 lb (86 kg)
Approximate net weight	180 lb (82 kg)

NOTE: For indoor use only

## Dimensional drawing

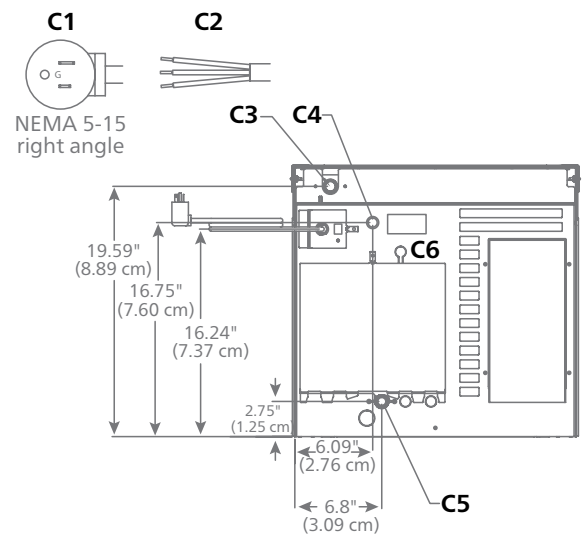
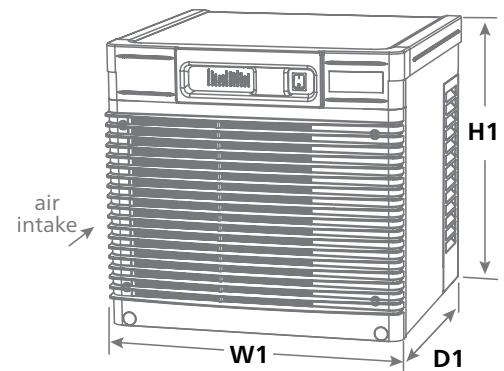

# 1 – Locating the ice machine

Horizon Elite self-contained Chewblet ice machines allow top-mounting or mounting in a base cabinet, on a wall or on a floor stand up to 75' (22.9 m) from the dispenser or ice bin with RIDE technology. In-cabinet mounting (RIDE applications) require special attention to service access, unit ventilation and ice tube runs (see pages 4-8).

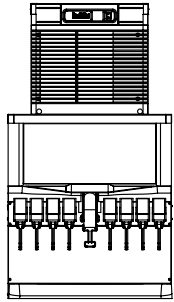
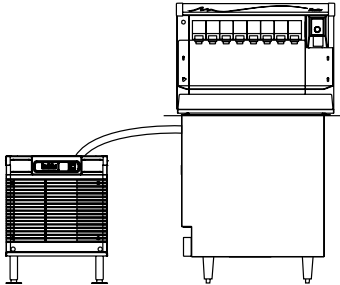
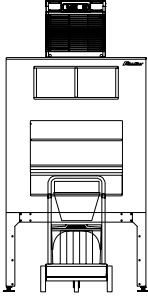
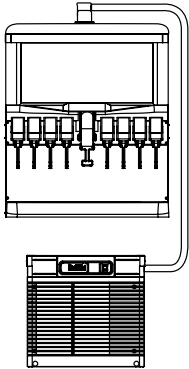
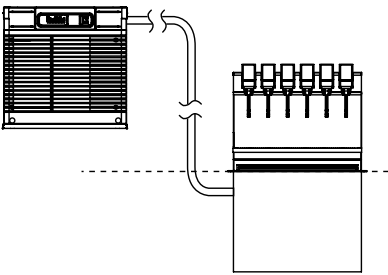
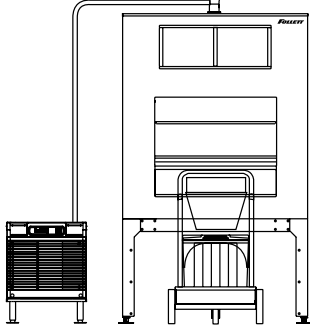
<p><b>Top mounting – ice and beverage dispensers (by others)</b></p>	<p><b>RIDE model – Follett low-profile Vision and Cornelius PR150 ice and beverage dispensers</b></p>	<p><b>Top mount on Follett ice storage bins</b></p>
		
<p><b>Important specifier notes</b></p> <ol style="list-style-type: none"> <li>1. Dispenser must be compatible with nugget ice. See page 4 for compatible ice and beverage dispenser models and top kit numbers.</li> <li>2. Verify ceiling or soffit height to ensure sufficient top clearance.</li> </ol>	<p><b>Important specifier notes</b></p> <ol style="list-style-type: none"> <li>1. See pages 4-6 for critical clearance and venting requirements.</li> <li>2. Ice transport tube ships with Vision ice and beverage dispenser (Vision applications only).</li> <li>3. Ice transport tube ships with Horizon Elite ice machine for Cornelius dispensers.</li> </ol>	<p><b>Important specifier notes</b></p> <ol style="list-style-type: none"> <li>1. See form# B300 for bin sizing.</li> <li>2. Verify ceiling or soffit height to ensure top clearance.</li> <li>3. Locate floor sink or grate and drains in front of storage bin.</li> <li>4. Do not position bin drain lines to block Ice•Device™ bin cart.</li> </ol>
<p><b>RIDE model – ice and beverage dispensers (by others)</b></p>	<p><b>RIDE model – drop-in beverage dispensers (by others)</b></p>	<p><b>RIDE model – Follett ice storage bins</b></p>
		
<p><b>Important specifier notes</b></p> <ol style="list-style-type: none"> <li>1. Dispenser must be compatible with nugget ice. Compatible dispensers include Servend MD150/175/200/250, SV175/200/250, MDH-402, and Follett Symphony Plus™ 110CM as well as the dispensers listed on page 4.</li> <li>2. Coca-Cola Freestyle 7000 requires top kit MSF30SC. Top adapter IC CODE 46412 and ice kit IC Code 46430 must also be ordered from Coca-Cola. Coca-Cola Freestyle 7100 requires top adapter IC Code 46751 and ice kit IC Code 46430 only, and must be ordered from Coca-Cola. Coca-Cola Freestyle 9100 requires top kit HSF26SC. Consult with Coca-Cola and Follett to qualify application prior to ordering.</li> <li>3. RIDE application is approved only for Pepsi Spire 3.0, 5.0 and 4.1 designed for top mount ice machines and requires MSP24SC for 3.0 and MSP30SC for 5.0 and 4.1, ordered separately. For manual fill versions of Pepsi Spire 3.0, 5.0 and 4.1, contact factory.</li> <li>4. See pages 4-6 for critical clearance and venting requirements.</li> </ol>	<p><b>Important specifier notes</b></p> <ol style="list-style-type: none"> <li>1. Compatible with the following dispensers: Cornelius 1522, 1722, 2323 and Lancer 2200, 2300, 23300.</li> <li>2. Requires 12.00" (30.5 cm) of access space for installation on transport tube side.</li> <li>3. See page 5-6 for critical clearance requirements.</li> </ol>	<p><b>Important specifier notes</b></p> <ol style="list-style-type: none"> <li>1. See form# B300 for bin sizing.</li> <li>2. Locate floor sink or grate and drains in front of storage bin.</li> <li>3. Do not position bin drain lines to block Ice•Device bin cart.</li> </ol>

## 1 – Locating the ice machine (continued)

Top mounting – compatible ice and beverage dispensers <sup>1</sup>					
Manufacturer	Model number	Width in (cm)	Depth <sup>2</sup> in (cm)	Height <sup>3</sup> in (cm)	Top kit
Coca-Cola dispensers	Freestyle 7000	30.10 (76.5)	33.11 (79.0)	47.00 (119.4)	H22F30-F <sup>4,5</sup>
	Freestyle 7100	30.00 (76.2)	33.80 (85.8)	47.00 (119.4)	H22F30-F <sup>4,6</sup>
	Freestyle 9000	25.50 (64.8)	35.50 (90.2)	73.75 (187.3)	H22F24-F <sup>4,7</sup>
	Freestyle 9100	25.50 (64.8)	39.25 (99.7)	77.25 (196.2)	H22F26-F <sup>4</sup>
Cornelius dispensers	DB/ED/DF 150 series	22.00 (55.9)	30.75 (78.1)	35.63 (90.5)	H22C22-F
	DB/ED/DF 175 series	24.50 (62.2)	30.00 (76.2)	35.63 (90.5)	H22C24-F
	DB/ED/DF 200 series	30.00 (76.2)	30.95 (78.6)	35.63 (90.5)	H22C30-F
	DB/ED/DF 250 series	30.00 (76.2)	30.95 (78.6)	39.63 (100.7)	H22C30-F
	DB/ED/DF 300 series	44.38 (112.7)	30.00 (76.2)	39.63 (100.7)	H22C44-F or B <sup>8</sup>
	FlavorFusion / Overload	30.00 (76.2)	33.00 (83.8)	41.00 (104.1)	H22C30-F-FF
	IDC215	30.00 (76.2)	29.88 (75.9)	36.69 (93.2)	H22C30-F-IDC
	IDC255 and Pro Fast Gate	30.00 (76.2)	33.13 (84.2)	39.75 (101.0)	H22C30-F-IDC <sup>9</sup>
Lancer dispensers	4500-22N	22.00 (55.9)	30.50 (77.5)	36.66 (93.1)	H22L22-F
	4500-30N	30.00 (76.2)	30.50 (77.5)	36.66 (93.1)	H22L30-F
	FS-22N	22.00 (55.9)	30.50 (77.5)	41.28 (104.8)	H22L22-F
	FS-30N	30.00 (76.2)	30.50 (77.5)	41.28 (104.8)	H22L30-F
	Bevariety	30.00 (76.2)	31.00 (78.7)	37.75 (95.9)	H22L30-F-STP
	Sensation 30"	30.00 (76.2)	31.00 (78.7)	38.25 (97.2)	H22L30-F-STP
	Sensation 44"	44.00 (111.8)	31.00 (78.7)	39.38 (100.0)	H22L44-F-STP
	Touchpoint	32.50 (82.6)	33.70 (85.6)	40.00 (101.6)	H22L30-F-STP
Pepsi dispensers	Spire 3.0	27.00 (68.6)	35.00 (88.9)	38.12 (96.8)	H22P24-F
	Spire 5.0 / 4.1	30.50 (77.5)	36.00 (91.4)	42.75 (108.6)	H22P30-F
Servend dispensers	MDH-302	42.75 (108.6)	30.50 (77.5)	35.16 (89.3)	H22S44-F or B <sup>8</sup>

<sup>1</sup> All approved dispensers can be filled with a RIDE model Horizon Elite ice machine without a top kit except Coca-Cola Freestyle 7000 and Pepsi Spire 3.0, 5.0 and 4.1, see page 3 for details.

<sup>2</sup> Requires minimum 1.00" (2.54 cm) clearance between back of dispenser and wall.

<sup>3</sup> Net height after installation of top kit (excluding height of ice machine).

<sup>4</sup> Consult with Coca-Cola and Follett to qualify application prior to ordering.

<sup>5</sup> Top adapter IC Code 46412 and ice kit IC Code 46430 must also be ordered from Coca-Cola.

<sup>6</sup> Top adapter IC Code 46753 and ice kit IC Code 46430 must also be ordered from Coca-Cola.

<sup>7</sup> Adapter must also be ordered from Coca-Cola. IC Code: 46010 (Silver), 46011 (Red) or 46012 (Black).

<sup>8</sup> Specify "F" for front facing, or "B" for backward facing units.

<sup>9</sup> Contact factory regarding IDC Pro.

## 2 – Undercounter/in-cabinet mounting

Cabinet details	
<p><b>Important specifier notes</b></p> <ol style="list-style-type: none"> <li>1. Cabinet door opening must meet minimum size requirements shown and be free of obstructions to allow ice machine to slide out (no lip or utilities to block removal).</li> <li>2. Cabinet base must be capable of supporting ice machine and allow ice machine to rest flat on cabinet bottom.</li> <li>3. No counter supports, electric or plumbing can run in front of the ice machine.</li> </ol>	<p><b>Cabinet door opening</b> 24.00"W x 22.25"H (60.9 cm x 56.5 cm) minimum</p> <p><b>slides out</b></p> <p><b>Cabinet base</b> must be flat and free of obstructions (no lip or utilities to block removal)</p>

### 3 – Undercounter/in-cabinet mounting and ventilation

#### Using Follett supplied grilles

Horizon Elite ice machines can be installed undercounter/in-cabinet to fill bins or dispensers using RIDE technology. Care must be taken to ensure proper cabinet venting to avoid recirculation of hot air. Improper venting can cause ice machine outages.

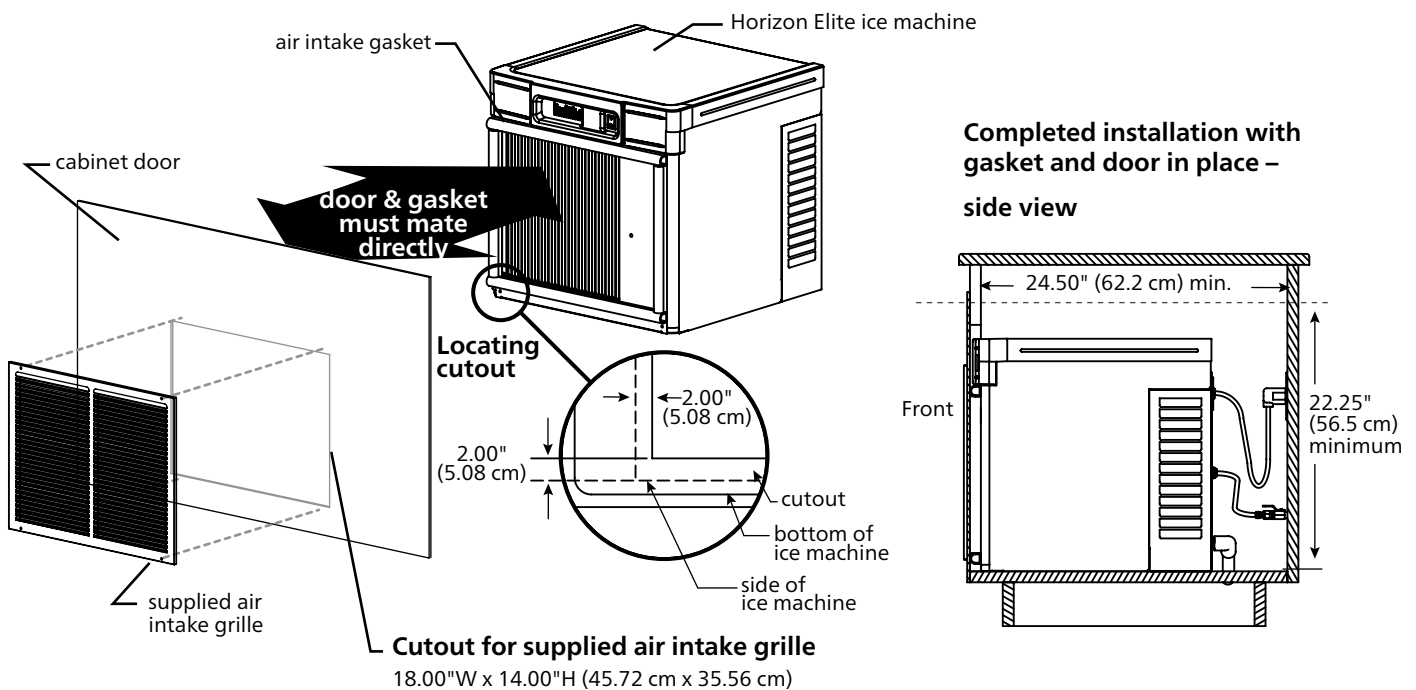
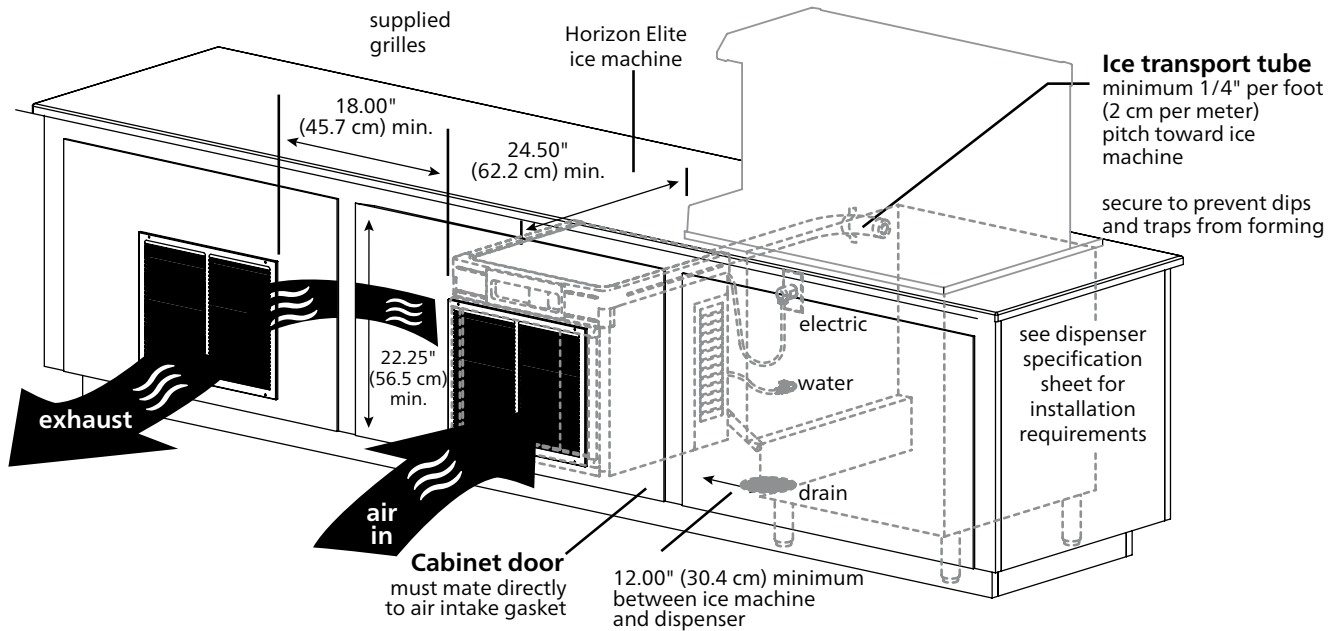

#### Important specifier notes for using Follett supplied grilles

1. The supplied exhaust grille must be located at least 18.00" (45.7 cm) from the supplied air intake grille (exhaust air must not recirculate with intake air).
2. Cabinet interior must be open to allow for unrestricted exhaust air flow.
3. Ice transport tube needs minimum 1/4" per foot (2 cm per meter) pitch toward ice machine and should be secured to prevent dips and traps from forming.
4. Cabinet door must mate directly to air intake gasket.
5. Cabinet interior must provide a minimum clear space of 24.50" (62.2 cm) deep by 22.25" (56.5 cm) high.
6. Cutout for supplied grilles must meet minimum size requirements shown above.
7. Utilities should be conveniently located as shown.

### 3 – Undercounter/in-cabinet mounting and ventilation (continued)

#### Using grilles by others/alternate cabinet ventilation

Cabinets with ventilation or louvers other than those provided require special consideration to provide proper ventilation. Recirculation of hot air will reduce ice machine performance and can cause ice machine outages.

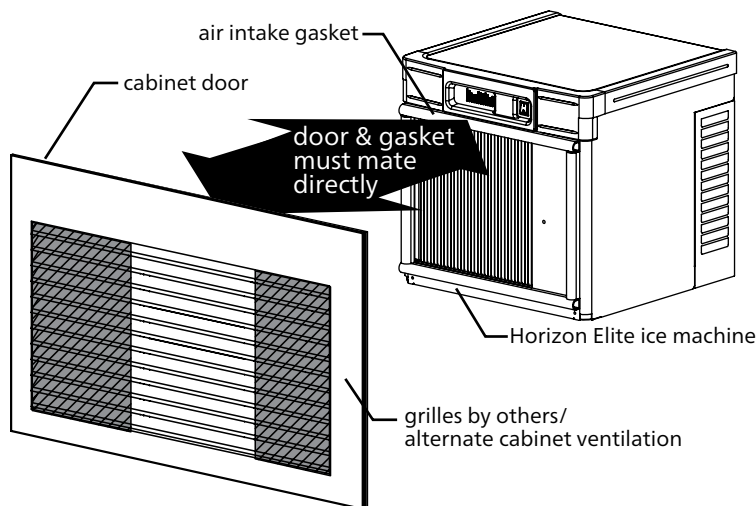
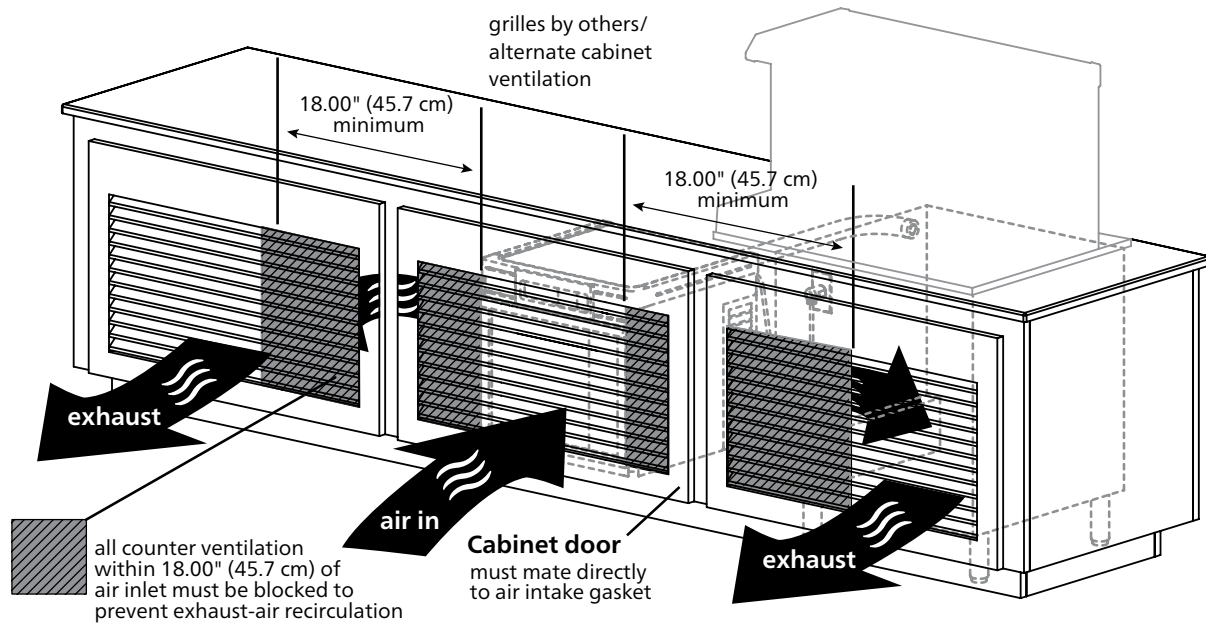

#### Minimum open air space

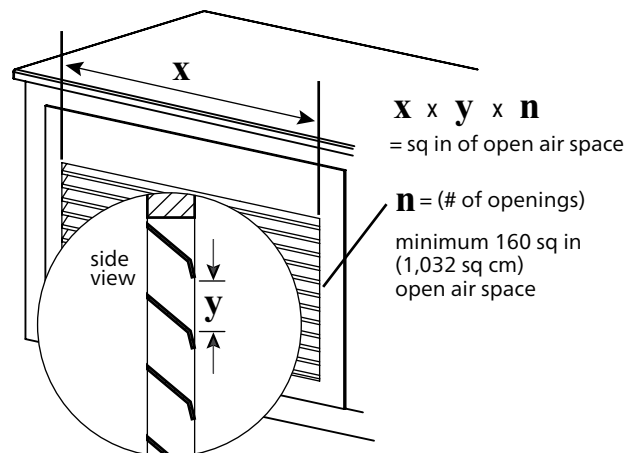

#### Important specifier notes for using grilles supplied by others/alternate cabinet ventilation

1. Exhaust must be at least 18.00" (45.7 cm) from air intake (exhaust air must not recirculate with intake air).
2. Cabinet interior must be open to allow for unrestricted exhaust air flow.
3. Ice transport tube needs minimum 1/4" per foot (2 cm per meter) pitch toward ice machine and should be secured to prevent dips and traps from forming.
4. Ducting must be provided if cabinet door does not mate directly to air intake gasket.
5. Cabinet interior must provide a minimum clear space of 24.50" (62.2 cm) deep by 22.25" (56.5 cm) high.
6. Grilles by others must meet minimum requirements for open air space shown above.
7. Utilities should be conveniently located as shown.

## 4 – Horizon Elite ice machine mounting accessories

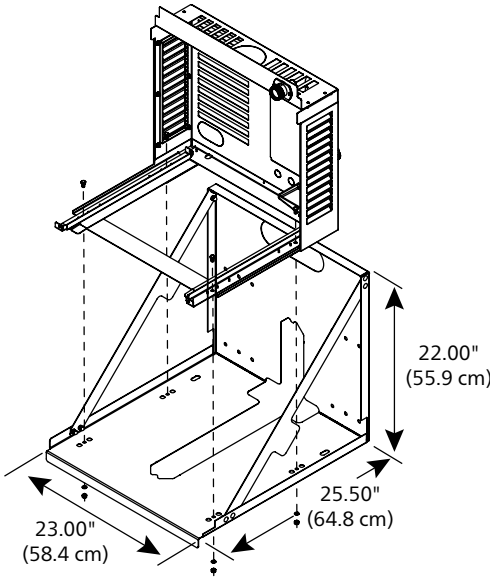
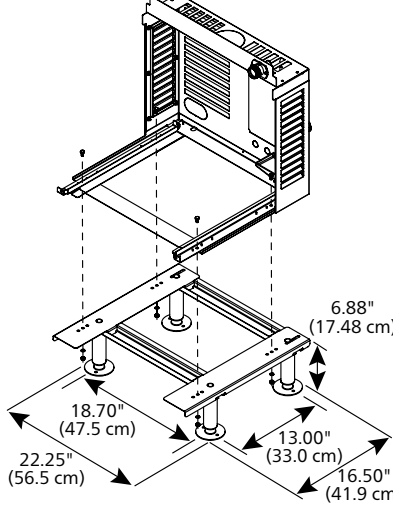
Optional wall mount bracket	Optional machine stand	Important specifier notes
 <p>22.00" (55.9 cm) 25.50" (64.8 cm) 23.00" (58.4 cm)</p>	 <p>6.88" (17.48 cm) 18.70" (47.5 cm) 22.25" (56.5 cm) 13.00" (33.0 cm) 16.50" (41.9 cm)</p>	<ol style="list-style-type: none"> <li>For secure wall mounting, specify optional wall mount bracket.</li> <li>Wall and fasteners must support the weight of the ice machine, bracket, supply water and ice. Use of a backing board may be required with hollow wall construction.</li> <li>Machine stand mounting adds 6.88" (17.48 cm) to height of ice machine.</li> <li>No dips in tube routing allowed.</li> <li>Ice transport tube needs minimum 1/4" per foot (2 cm per meter) pitch toward ice machine and should be secured to prevent dips and traps from forming.</li> </ol>

## 5 – Horizon Elite drain - specifier guidelines

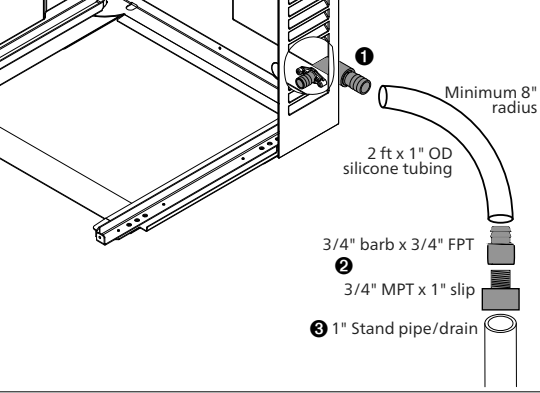
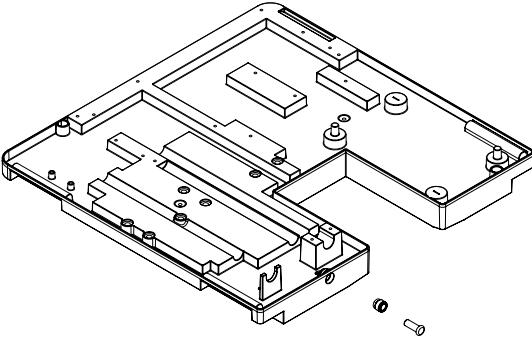
Flush drain plumbing – For regular machine drainage	Important specifier notes: Where code allows, follow recommendation below.
 <p>Minimum 8" radius 2 ft x 1" OD silicone tubing 3/4" barb x 3/4" FPT 3/4" MPT x 1" slip 1" Stand pipe/drain</p>	<ol style="list-style-type: none"> <li>Connect the silicone tubing to the ice machine 3/4" drain barb ❶.</li> <li>Assemble the 3/4" barb x 3/4" FPT to the 3/4" MPT x 1" slip. Connect the other end of the silicone tubing to the 3/4" barb ❷.</li> <li>Connect the 1" slip fitting to the 1" stand pipe/drain ❸.</li> </ol> <p>Note: Minimum 8" radius on silicone drain line. Drain line from the ice machine must have at least 1/4" per foot pitch (6.4 mm/0.3 m).</p> <p>Note: Stand pipe/drain provided by others. All other components provided with ice machine.</p>
Chassis drain plumbing – To assist with condensate in high humidity areas	Important specifier notes: Where code allows, follow recommendation below.
	<ol style="list-style-type: none"> <li>Plug must be removed from John Guest fitting.</li> <li>Route 3/8" drain tubing through knockout in back of docking station and insert fully into John Guest fitting connection at the rear of the machine chassis. Route other end of 3/8" drain tubing to drain.</li> <li>Drain must slope 1/4" inch per foot (6 mm per 30.4 cm).</li> </ol>

## 6 – Horizon Elite ice tube runs - specifier guidelines

### Long tube runs for RIDE remote ice delivery equipment

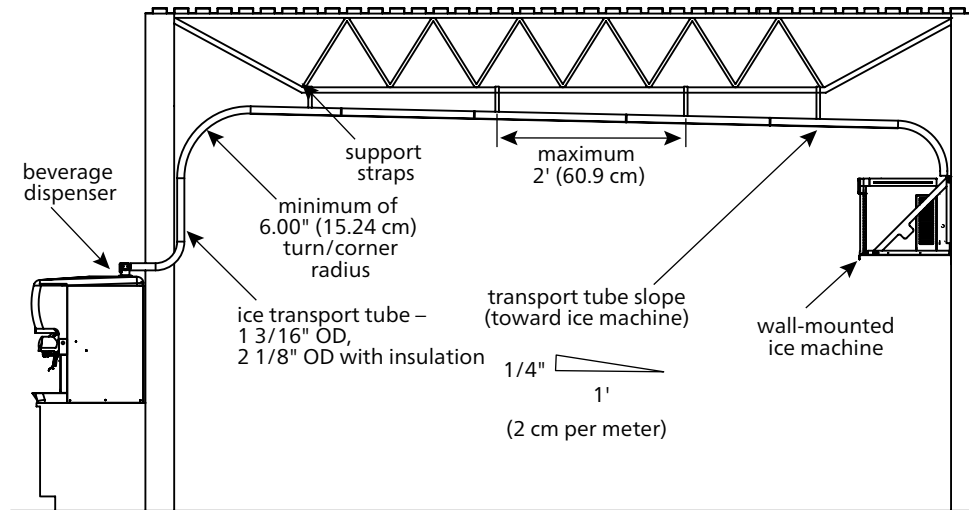

### Important specifier notes

- 75' (22.9 m) maximum ice transport tube run.
- Tubing routing bends must have a 6.00" (15.24 cm) radius or larger.
- Dips and traps are not allowed. If not supported from underneath, secure insulated ice transport tube at least every 2' (60.9 cm) to prevent drips and traps.
- Relative humidity levels above 80% in areas where the ice machine or ice transport tube is located may produce excessive condensation that will cause water damage.
- Contact factory for recommendations on running tubing through a decorative soffit or chase.

### Ice production – Horizon Elite 710 series, air-cooled 60 Hz

Inlet water temperature F (C)	Ambient air temperature F (C)					lb (kg) production in 24 hr
	60 (16)	70 (21)	80 (27)	90 (32)	100 (38)	
50 (10)	787 (357)	759 (345)	705 (320)	639 (290)	603 (274)	
60 (16)	750 (341)	702 (319)	666 (302)	624 (283)	570 (259)	
70 (21)	707 (321)	681 (309)	636 (289)	586 (266)	542 (246)	
80 (27)	677 (307)	629 (286)	611 (277)	559 (254)	518 (235)	
90 (32)	642 (291)	600 (272)	580 (263)	539 (245)	497 (226)	

### Ice production – Horizon Elite 710 series, air-cooled 50 Hz

Inlet water temperature F (C)	Ambient air temperature F (C)					lb (kg) production in 24 hr
	60 (16)	70 (21)	80 (27)	90 (32)	100 (38)	
50 (10)	664 (301)	617 (280)	576 (261)	538 (244)	500 (227)	
60 (16)	645 (293)	601 (272)	560 (254)	521 (236)	481 (218)	
70 (21)	626 (284)	582 (264)	544 (247)	506 (229)	464 (210)	
80 (27)	588 (267)	544 (247)	512 (232)	481 (218)	389 (176)	
90 (32)	557 (252)	519 (235)	487 (221)	455 (207)	328 (149)	



ENERGY STAR and the ENERGY STAR mark are registered trademarks owned by the U.S. Environmental Protection Agency.

Agion is a registered trademark of Sciesent LLC.

HORIZON ELITE, ICE•DEVICE, MICRO CHEWBLET, SAFECLEAN PLUS, SANISPONGE, SYMPHONY PLUS and VISION are trademarks of Follett LLC.

CHEWBLET, FOLLETT and RIDE are registered trademarks of Follett LLC, registered in the US.

Follett reserves the right to change specifications at any time without obligation. Certifications may vary depending on country of origin.

### Self-contained 710 series ice machine