



MODEL:

HGX-T-10-F

HYGENIKX+®



HyGenikx 'F' range Air and Surface Sanitisation unit – designed for food storage, preparation and service, this includes chilled food storage areas. Covers 10m². Supplied with a food safe shatter-proof lamp.

Area of Use: Food
Colour finish: Titanium
Lamp Type: ORANGE (HGX-10-F) Food Safe
Range of Cover: 10m²

FEATURES & BENEFITS

- Uses proven UVC technology to improve air quality, extend shelf-life of fresh food, and control odours
- Targets and kills biological hazards, including Salmonella, Escherichia coli (E. coli), Norovirus and other primary sources of infections
- Laboratory tested and proven to eliminate harmful Listeria and remove up to 99.99% of viruses, including Coronavirus. For more information visit: <https://info.mechline.com/hygenikx-testing>
- Eliminates bacteria, viruses, moulds, fungi and volatile organic compounds (VOCs), both in the air and on exposed surfaces, even in the hardest to reach places
- Fully tested and environmentally compliant
- Proven to deplete harmful Listeria monocytogenes and Listeria innocua from surfaces to undetectable levels
- Low power consumption, 9-13W
- Easy to change lamp (and battery), requires no onsite engineer
- Power via a plug that allows flexible installation and easy connection to existing isolated socket or fused spur

TECHNICAL INFO

- Combines technologies: Germicidal Oxidation, Germicidal Irradiation, Dual waveband Plasma Quatro
- Lamp (and battery) requires replacement every 12 months to ensure peak efficiency
- Unit dimensions: 400 x 135 x 110mm
- Rated voltage: 230V
- Operating voltage: 220-230V
- Uninterrupted supply – 24 hour operation required. High level
- 1m (usable length) power cable with plug to be connected to suitably isolated socket or fused spur. Plug type supplied is dependent on country/location. 3-pin (type G), or 2-pin (type C) Europlug
- EC declaration of conformity
- CE and UKCA mark
- Low Voltage Directive (LVD) 2014/35/EU
- Electromagnetic Compatibility Directive (EMC) 2014/30/EU
- Manufactured in accordance with European standards
- Produced under the control of our comprehensive BSI ISO 9001:2015 Quality Management System (certificate FS 616985)
- Class II certified for electrical insulation

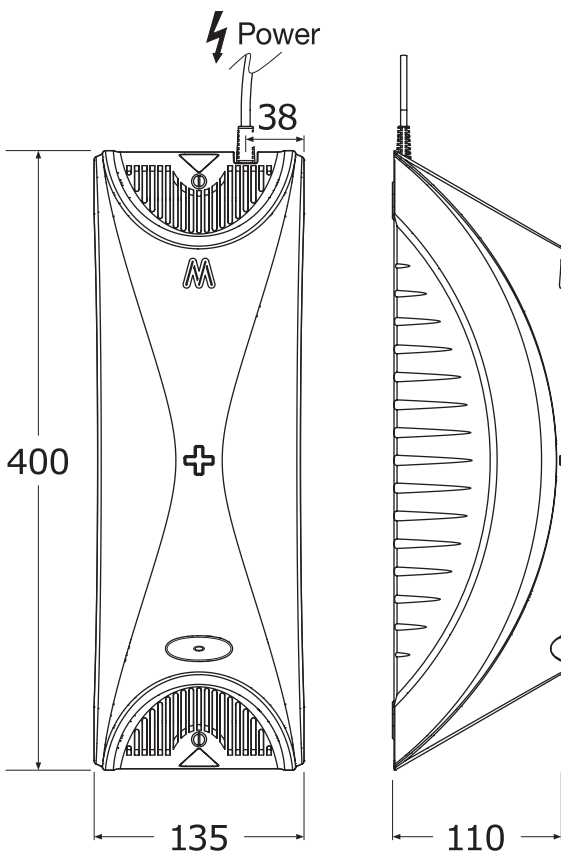

Manufactured by Mechline Developments Ltd.
 If a CAD file is required please contact technical@mechline.com

Rev: 03/2023