



Shown with SmartCART™ 75,
other configurations available

Single door Ice•Devlce™

ice storage, dispensing and transport systems

Features

Designed with speed, safety and sanitation in mind

- elevated ice storage bin uses gravity to dispense ice through a chute seven times faster than scooping
- dispensing directly into cart eliminates scooping by hand to help prevent cross-contamination
- industry exclusive SmartGATE® ice shield controls the flow of ice to reduce spill and limit contact with ice
- locks in three positions and returns easily to full down position

Fresher ice

- first ice in is first ice out

Ice compatibility

- compatible with most non-flake ice types, including customer preferred Chewblet® ice

Durable, user-friendly construction

- full stainless bin exterior and base
- corrosion-resistant poly bin liner and ABS top
- heavy duty "stay-open" PowerHinge™ door hinge – easy one hand open and close without door catches

SmartCART 75 ice cart fits through narrow aisles

- oversized back wheels for easy maneuverability
- holds 75 lb (34 kg) of ice in three Totes™ ice carriers

Easy installation

- comes with ice access door assembly attached to body of bin
- only 31.00" (78.7 cm) wide to fit through standard door openings by removing front door assembly (4 screws, no sealant)
- drain elbow with 1.00" (2.54 cm) barb fitting provided

Includes:

- custom-cut non-corroding ABS top for most popular ice machines
- Flexi-Top™ ice bin top system for 48.00" (121.9 cm) and 60.00" (152.4 cm) wide models
- optional Flexi-Tops make stocking bins simple – allows many ice machines to fit one top
- one SmartCART 75 ice transport cart with three removable Totes ice carriers (refer to chart on reverse for other configurations)
- 82 oz plastic ice scoop
- paddle and rake tool set with hanging bracket

Gravity ice dispense eliminates scooping



Accessories

Additional carts and accessories (refer to form# 3435)

Follett Europe Polska Sp. z o.o.
Mokry Dwór 26C 83-021 Wiślina, Poland
+48 (58) 785-6140 | Fax: +48 (58) 785-6159
folletteurope.com

801 Church Lane | Easton, PA 18040, USA
1.610.252.7301 | Fax: +1.610.250.0696 | follettice.com

Job
Item

FOLLETT®

Specification

Maximum bin capacity ¹	see model table below
W1 Bin width	see model table below
D1 Bin depth	31.00" (78.7 cm)
Bin depth with lower door assembly ²	39.00" (99.1 cm)
D2 Bin depth with door fully extended	49.50" (125.7 cm)
H1 Bin height ³ (adjustable)	see model table below
H2 Bin base height ⁴ (adjustable)	24.75" (62.9 cm)
H3 Bin base clearance ⁵ (adjustable)	21.62" (54.9 cm)
Required door access ⁵	32.00" (81.3 cm)
W2 Cart width	21.50" (54.6 cm)
D3 Cart depth	34.00" (86.4 cm)
H4 Cart height at front edge	20.50" (52.1 cm)
H5 Cart height with lid up	38.62" (98.1 cm)
L1 Drain ⁶	1.00" FPT, center of bin bottom (drain elbow supplied)
Dispense rate	up to 5 lb (2.3 kg) per second
Ice compatibility	cube ice and Chewblet ice
Approximate ship weight	see model table below

NOTE: For indoor use only

SHORT FORM SPECIFICATION: Ice•Device system to be Follett model _____ elevated bin, base, and ice transport cart system with front ice chute and industry-exclusive SmartGATE ice shield. Bin to hold approximately _____ lb (kg) of ice. Exterior finish of bin and base to be full stainless front, sides, back and bottom. Bin liner to have non-corroding polyethylene walls and stainless steel bottom. Bin insulation to be non-CFC polyurethane foam, bonded to shell and liner for added structural strength. Bin top to be ABS and custom-cut for ice machine(s) to be used. Lower door assembly to include non-corroding poly access door, poly lift door with PowerHinge to eliminate gasket and latches, and inner SmartGATE to positively control ice flow into access door area. Entire lower door assembly to be easily removable for installation through narrow doors. Upper inspection window (on all models except DEV500SG-30, DEV860SG-48 and DEV1080SG-30) to be double-wall poly to increase durability and minimize ice melt and condensation. Cart base to be rotomolded polyethylene with hinged plastic lid and drain. Totes to be of one-piece, molded poly with swivel handle. Cart and Totes to store below bin when not in use. All models to be equipped with flanged, adjustable feet, paddle and rake tool set. NSF-listed.

Warranty:

Follett LLC warrants to the original end user that the cabinet exterior, including the top and trim, and the interior liner will be free of corrosion for the useful life of the product. Parts and labor for corrosion repair are covered under this warranty. All other integral components are covered against defects in material and workmanship under normal use and service for a period of 5 years from the date of installation. Date of installation shall not exceed 90 days from date of shipment. Parts and labor for repair within this 5 year period are covered under this warranty. Removal of ice machine to service bin and any labor costs incurred are expressly excluded from this warranty.

Model	with SC75 cart	with SC125 cart	with Cambro cart	with Totes ice carrier ⁴	with bagger kit ⁸	Maximum bin capacity lb (kg) ¹	Cubic Volume cu ft (m)	Width - W1 in (cm)	Height ^{3,4} - H1 in (cm)	Approximate ship weight lb (kg)
DEV500SG-30 ⁷	-75	-125	-ICS125L	-LP	-BG	460 (209)	14.80 (0.41)	30.00 (76.2)	63.00 (160.0)	354 (161)
DEV700SG-30	-75	-125	-ICS125L	-LP	-BG	680 (308)	21.70 (0.61)	30.00 (76.2)	78.50 (199.4)	389 (177)
DEV860SG-48 ⁷	-75	-125	-ICS125L	-LP	-BG	860 (390)	25.50 (0.72)	48.00 (121.9)	65.50 (166.4)	452 (206)
DEV1010SG-48	-75	-125	-ICS125L	-LP	-BG	1000 (454)	31.90 (0.90)	48.00 (121.9)	74.50 (189.2)	453 (206)
DEV1175SG-48	-75	-125	-ICS125L	-LP	-BG	1185 (538)	37.60 (1.06)	48.00 (121.9)	80.50 (204.5)	483 (219)
DEV1300SG-48	-75	-125	-ICS125L	-LP	-BG	1320 (599)	41.90 (1.19)	48.00 (121.9)	84.00 (213.4)	476 (216)
DEV1160SG-56	-75	-125	-ICS125L	-LP	-BG	1170 (531)	37.30 (1.06)	56.00 (142.2)	74.50 (189.2)	472 (214)
DEV1350SG-56	-75	-125	-ICS125L	-LP	-BG	1360 (617)	43.20 (1.22)	56.00 (142.2)	80.50 (204.5)	521 (236)
DEV1080SG-60 ⁷	-75	-125	-ICS125L	-LP	-BG	1080 (490)	34.30 (0.97)	60.00 (152.4)	65.50 (166.4)	490 (222)
DEV1325SG-60	-75	-125	-ICS125L	-LP	-BG	1325 (601)	42.00 (1.19)	60.00 (152.4)	74.50 (189.2)	518 (235)
DEV1475SG-60	-75	-125	-ICS125L	-LP	-BG	1490 (676)	47.40 (1.34)	60.00 (152.4)	80.50 (204.5)	517 (235)
DEV1650SG-60	-75	-125	-ICS125L	-LP	-BG	1660 (753)	52.80 (1.50)	60.00 (152.4)	84.00 (213.4)	532 (241)

Notes:

- Computed on cubic volume of bin. Does not reflect cart capacity or voids that can occur due to pyramiding.
- Lower door assembly easily removed for installation access.
- Special top required for ice machines weighing more than 1000 lb (454 kg). Add 0.5" (1.27 cm) to height. Contact factory.
- 10.00" (25.4 cm) flanged legs available which replace base unit, height from floor to bottom of chute equals 15.50" (39.4 cm), overall height reduced by 9.75" (24.8 cm). Includes one Totes ice carrier instead of cart and uses 4.00" (10.16 cm) chute.
- Required clearance for installation access through doors (may require removal of lower door assembly).
- Follett recommends installation of a floor drain with grate with all ice storage bins. Consider cart positioning when locating the drain. Clearance required to pull cart from below bin — minimum 36.00" (91.4 cm), optimal 40.00" (101.6 cm).
- DEV500SG-30, DEV860SG-48 and DEV1080SG-60 do not have upper inspection window.
- Bagger kit includes 250 plastic bags of 10 lb (4.5 kg) capacity.

Dimensional drawing

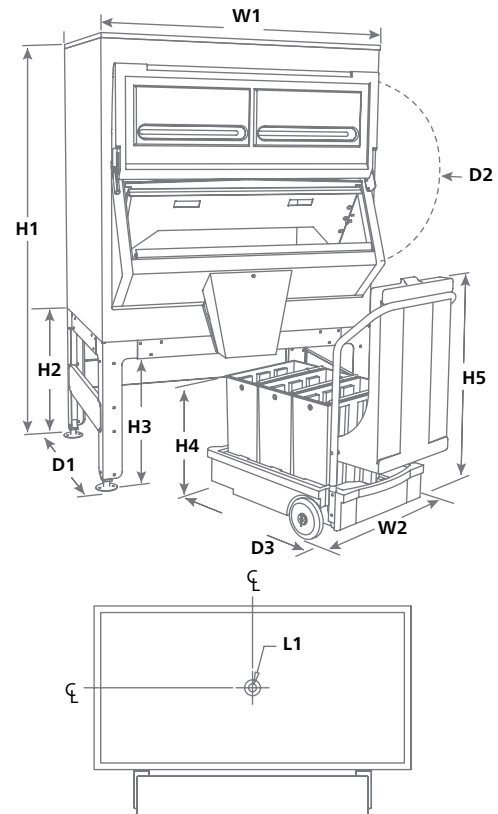

Flexi-Top, Ice•Device, PowerHinge, SmartCART and Totes are trademarks of Follett LLC. Chewblet, Follett and SmartGATE are registered trademarks of Follett LLC, registered in the US. Follett reserves the right to change specifications at any time without obligation. Certifications may vary depending on country of origin.

