



UCG135APD GOURMET SERIES UNDERCOUNTER WITH PUMP OUT DRAIN

COAST ICE & COLD SOLUTIONS



UCG135APD

Features

- WITH PUMP OUT DRAIN
- Maximum drain height 1 metre.
- Maximum drain length 4 metres.
- 2 metres of drain hose included in installation kit.
- Produces clear, long-lasting gourmet cubes.
- Space-saving 463 mm wide under-counter design.
- Produces up to 58 kg of ice per day.
- Castors optional - bringing height down to 839mm
- Constructed from sturdy, corrosion-resistant stainless steel and fingerprint-proof plastic.
- Ideal for any under-counter or bar application.
- Contemporary, elegant design.
- Environmentally friendly R134A refrigerant.
- Easily adjust the thickness of your ice from the front of the machine!

Space-Saving Solutions

- Front air discharge design for compact spaces.
- Low profile top saves counter space.
- Stores up to 22 kg of ice.
- Easy front access to ice.
- Removable Air Filter.

Options & Accessories

WATER FILTERS		
Ice Machine Model	Manifold	
	System	Replacement
UCG135APD	CD1oB	CD1o0B

Ice Maker Warranty

Every Ice-O-Matic ice maker is backed by a warranty that provides both parts and labor coverage.

- Two years Parts and Labour

Ice Form



GOURMET ICE

GOURMET ICE DIMENSIONS

Height	30.5 mm
Diameter	34.25 mm

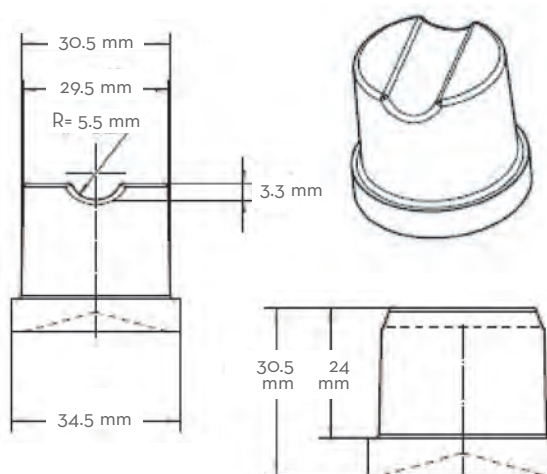



UCG135APD GOURMET SERIES UNDERCOUNTER WITH PUMP OUT DRAIN

UCG135APD GOURMET SERIES UNDERCOUNTER WITH PUMP OUT DRAIN

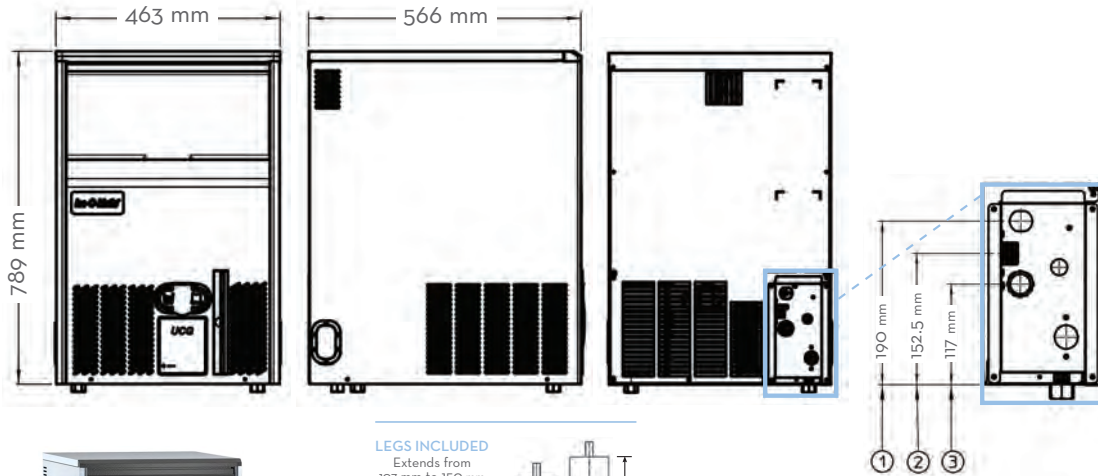

- 1 - Power Cord
- 2 - 19 mm Water Inlet
- 3 - 20 mm Water Drain

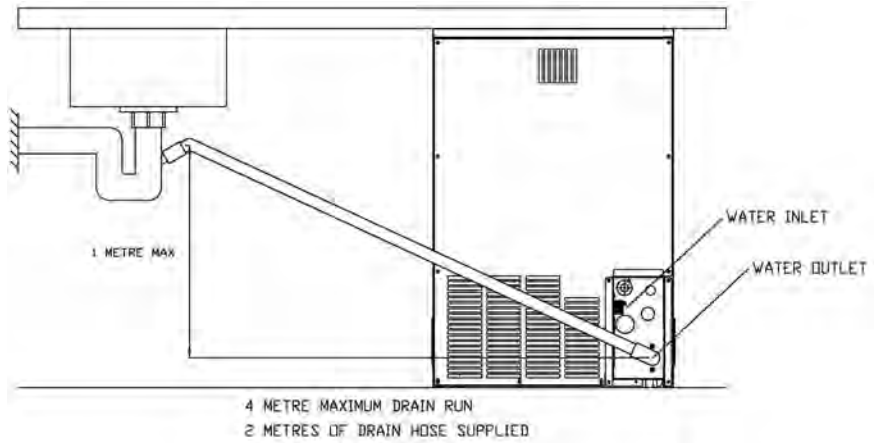
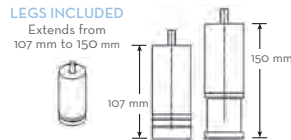

Operating Requirements

	MINIMUM	MAXIMUM
	50 Hz	
Ambient Temp. Range Air	10 °C	43 °C
Water Temp.	5 °C	38 °C
Water Pressure	1 BAR	5 BAR
Electrical Voltage	230V/50Hz/1ph	

Dimensions

ALL MODELS	
W x D x H (mm)	463 x 566 x 896-939 on legs
839mm high on castors	

Specifications

Model Number	Cond. Unit	Ice Production per 24hrs	Ice Production per 24hrs	Ice Production per 24hrs	Storage Capacity (kg)	Water Consumption (ltr/hr)	kWh Used per 45 kg of Ice @ 32°C air/ 21°C water	Voltage Characteristics
		21°C air/10°C water (kg)	32°C air/21°C water (kg)	10°C air/10°C water (kg)				
UCG135APD	Air	58	47	57	22	6	9	230/50/1

NOTES:
 Approx. Shipping Weight (kg): UCG135APD (37)
 Refrigerant Type: R134A
 All specifications and performance data are subject to normal manufacturing variances.

Ice-O-Matic reserves the right to change the specifications at any time without obligation. Certifications may vary depending on country of origin.