

# Undercounter and Freestanding Integrated Icemaker with Drain Pump

425 series for foodservice applications



## Features

Integrated ice machine with bin, now available with drain pump. Up to 193 kg of production and 36 kg of storage capacity. Perfect for space limited facilities when sewerage installations don't allow to use standard gravity drainage. Less than 61.0 cm wide, the integrated icemaker will provide the capacity you need in a small footprint.

Undercounter application without the legs: 83.8 cm tall unit will fit under standard counters. Teflon glides allow it to slide easily into place. Freestanding: 99.1 cm tall with legs.

Consumer-preferred Micro Chewblet™ ice (also available as a flaker)

- preferred over cubes by more than 2:11
- easy to chew
- slow melting, maintains drink temperature and quality, comparable to cubes
- higher displacement than cube ice

Flake ice is perfect for display

- securely supports salad bar containers without tipping
- cradles fish and vegetables without bruising

High performance ice machines

- stainless steel evaporator, auger and top bearing provides durability
- oversized, heavy duty, tapered roller bearing ensures long low-maintenance life
- semi-automatic cleaning cycle reduces maintenance costs
- regular flushing improves ice quality and reduces scale

Lower utility bills

- energy-efficient, no costly defrost cycles
- 25% less energy than comparable capacity cube machines
- 40% less water than comparable capacity cube machines

Designed for easy installation and service

- Integrated drain pump gives possibility to install device in place where draining installation is not available. Device can pump the waste water away up to 1.5m vertically and 5m horizontally
- Front ventilated - no side, top or back clearance required - rear utility access allows for rear electrical and plumbing connection with no rear clearance required
- Bin and shroud may be removed for service and maintenance

Warranty

- 3 years parts and labor, 5 years compressor parts

<sup>1</sup> Warranty is valid only when periodic maintenance and cleaning instructions is followed.

Ice Production	Ice type	V/Hz /Ph	Product no.	Item no.
193 kg	Micro Chewblet™	220/60/1	UMC425A80P <sup>1</sup>	01231174
		230/50/1	UME425A80P <sup>1</sup>	01208107
	Flake	220/60/1	UFC425A80P <sup>1</sup>	01231182
		230/50/1	UFE425A80P <sup>1</sup>	01217272

<sup>†</sup> ENERGY STAR® certified

<sup>1</sup> Model ships EXW Incoterms 2010 – Wislina, Poland. Models not for use in the United States.



Ice machine bin for foodservice

Ice machine bin for foodservice

## Specification

Ice storage capacity	34 kg
<b>W1</b> Width	59.7 cm
<b>D1</b> Depth	66.0 cm
<b>H1</b> Height with legs	99.0 cm
<b>H2</b> Height without legs	83.8 cm
Service and ventilation clearance	front ventilated - no side, top or back clearance required
Utility connection location	back
<b>C1</b> Electrical 230 V/60/1	3.8 amps, cord only
<b>C1</b> Electrical 230 V/50/1	5.1 amps, cord only
<b>C2</b> Potable water inlet	3/8" push in
<b>C3</b> Drain	3/8" push in
Air temperature	10 - 38 °C
Water temperature	4 - 32 °C
Potable water pressure	10 - 70 psi (69 - 483kpa) 0.7 Bar - 5 Bar max
Ice production at 21 C air and 10 C water	193 kg
Ice production at 32 C air and 21 C water	147 kg
Energy consumption 32 C air; 21 C water	5.4 kWh
Heat rejection	5,000 BTU/hr
Water consumption	45.4 L of potable water per 45.4 kg of ice
Approximate ship weight	84 kg

NOTE: For indoor use only. Designed for commercial use. Follett is not able to provide in-house services for residential installations.

Incoterms is a trademark of the International Chamber of Commerce.

ENERGY STAR and the ENERGY STAR mark are registered trademarks owned by the U.S. Environmental Protection Agency. Micro Chewblet™ is trademarks of Follett LLC.

Follett is a registered trademark of Follett LLC, registered in the US.

Follett reserves the right to change specifications at any time without obligation. Certifications may vary depending on country of origin.

## Dimensional drawing

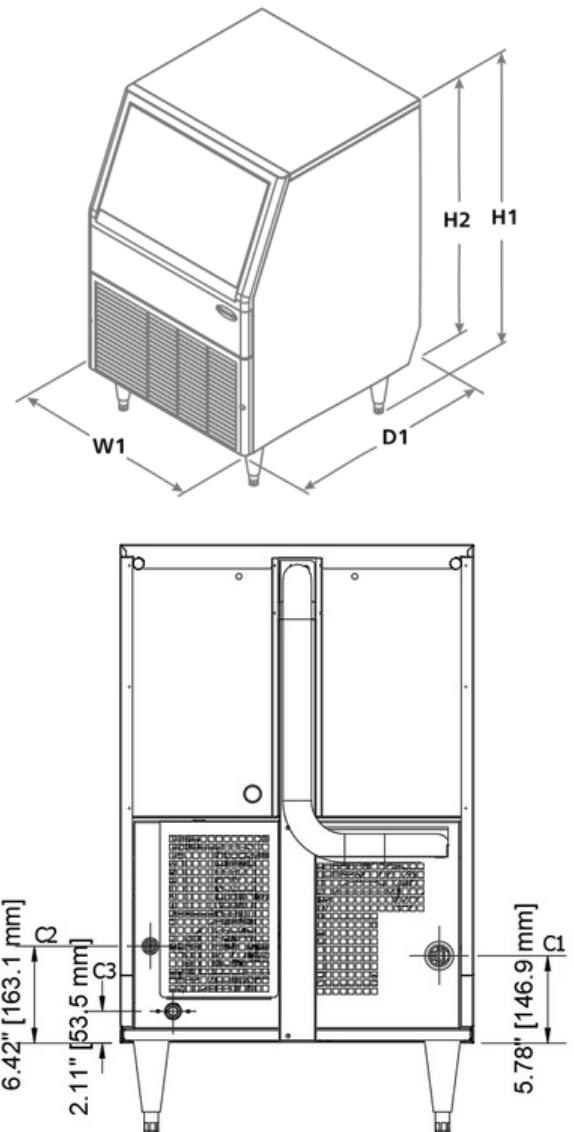

Ice machine bin for foodservice